

ADVERTISEMENT FOR BIDS

AUGUST 3, 2012

Sealed proposals will be received by the City of Fairhope of Baldwin County, Alabama, in the City of Fairhope offices, 555 South Section St. Fairhope, Alabama, until 2:00 P.M. September 4, 2012, and then publicly opened thereafter, for furnishing all labor and materials, and performing all work required by the City of Fairhope and described as follows:

Bid Number 013-12, BABY POOL RENOVATIONS

SIXTY (60) working days are allowed for the construction of the project.

Bid documents will be posted on the City of Fairhope Website: www.cofairhope.com or a copy may be obtained by e-mailing the Purchasing Manager at: dan.ames@cofairhope.com. Specifications are on file and may be seen in the Purchasing Department of the City of Fairhope, Alabama, 555 S. Section Street. Prior to opening, Bid packages may be picked up at that location during normal operation, between 7:00 am and 4:00 pm local time.

Questions or comments pertaining to this bid must be presented in writing, sent as e-mail to the attention of the Purchasing Manager, Daniel P. Ames, P.O. Drawer 429, 555 South Section St., Fairhope, Al 36532, e-mail: dan.ames@cofairhope.com, Seventy Two (72) hours prior to the bid opening or will be forever waived.

All bids must be on blank bid forms provided in the Bid Documents. Bids shall be accompanied by a Bid Security equal to 5% (percent) of the bid price, but in no event more than \$10,000.00. Bid Security shall be in the form of a Bid Bond signed by a bonding company authorized to do business in the State of Alabama, or a cashier's check payable to The City of Fairhope. No Bid Security is required on bids less than \$10,000.00.

A Performance Bond in the form and terms approved by the City of Fairhope in an amount not less than the sum bid will be required at the signing of the contract, and in addition, a bond in form and terms approved by the City of Fairhope in an amount not less than fifty percent (50%) of the contract price insuring payment for all labor and materials.

THERE WILL BE A MANDATORY PRE-BID MEETING ON MONDAY, AUGUST 13, 2012, AT 9:00 a.m. , at the RECREATION CENTER, 803 N Greeno Road, Fairhope, Al 36632. All prospective bidders shall have a representative present at the Pre-bid Meeting. All contractors not having a representative at this meeting will be disqualified from bidding on this project.

The City of Fairhope is an Equal Opportunity Employer and requires that all contractors comply with the Equal Employment Opportunity laws and the provisions of the Contract Documents in this regard. The City also encourages and supports the utilization of Minority Business Enterprises on this and all public bids.

All bids, with their guarantee (when required), must be enclosed in a sealed, opaque envelope, clearly identified on the outside as a "**Sealed Bid**" with **Item Name, Bid Number, City of Fairhope's Name and Address and Bidder's Name and Address**. Each bid must be in a separate envelope. Bids made out in pencil will not be accepted. Failure to observe the instructions contained herein will constitute grounds for rejection of your bid. The City reserves the right to accept or reject all bids or any portion thereof, and to waive informalities and to furnish any item of material or work to change the amount of the Contract, whichever is in the best interest of the City of Fairhope.

The Contractor must furnish to the City of Fairhope at the time of the signing of the contract a certificate of insurance coverage as provided in the contract documents which will include comprehensive insurance, Contractor's Automobile Liability Insurance, and where applicable, Owner's Protective Liability insurance, subcontractor's public liability and property damage insurance. The company that is awarded the bid must have Workman's Compensation Insurance on all of its employees if work is to be performed on City of Fairhope premises. General Liability Insurance, specifying coverage, must be maintained to hold the City of Fairhope harmless in the event of an accident. See bid packet for details.

No bids will be considered unless the bidder, whether resident or non-resident of Alabama, is properly qualified to submit a proposal for this type of work in accordance with all applicable laws of the State of Alabama. Where applicable, this shall include evidence of holding a current license from the State Licensing board for General Contractors, Montgomery, Alabama, as required by Chapter 8 of Title 34, of the Code of Alabama, 1975. In addition, the awarded vendor, if non-resident of the State, and if a corporation, shall show evidence of having qualified with the Secretary of State to do business in the State of Alabama. Bidder must have a current business license or purchase a business license with the City of Fairhope prior to work performed. No bids shall be withdrawn for the period of thirty (30) days subsequent to the opening of proposals without the consent of the City of Fairhope, Baldwin County, Alabama. Once completed, a tabulation of the responsive and responsible bids will be available for public viewing by visiting the following web address: www.cofairhope.com.

Daniel P. Ames, Purchasing Manager
City of Fairhope

Posted 08-03-12

CONTRACT DOCUMENTS
BID FORM AND SPECIFICATIONS

for
Bid No. 013-12
Baby Pool Renovations
for
Recreation Department
Project No. PW004-12
Baby Pool Renovations

FAIRHOPE CITY COUNCIL

Timothy M. Kant, Mayor
Lonnie L. Mixon, Council President

Set Number _____

TABLE OF CONTENTS

Invitation and Instruction to Bidders.....	I
Bid Form.....	II
Bonds.....	III
Insurance.....	IV
Contract.....	V
Scope of Work.....	VI
Standard Terms and Conditions.....	VII
Mandatory Alabama Immigration Requirements.....	VIII

**ITEM I
INVITATION AND INSTRUCTIONS TO BIDDERS**

1.00 BID INVITATION

Notice is hereby given that the City of Fairhope ("Owner") will receive bids on the project described herein. Qualified bidders are invited to bid on this contract.

1.01 PROJECT NAME: **BABY POOL RENOVATIONS**
LOCATION: **Fairhope Recreation Department, 803 N. Section Street**
PROJECT No. **PW004-12**

1.02 SUMMARY:

Supply and install Baby Pool Renovations as detailed in the attached Scope of Work and Specifications.

1.03 BID DEADLINE

Bids will be received until 2:00 p.m. local time, Tuesday, September 4, 2012, at the City of Fairhope Offices, 555 South Section St., Fairhope, Alabama, and publicly opened shortly thereafter.

1.04 AVAILABILITY OF DOCUMENTS

Bid Documents may be obtained at the City of Fairhope Offices, 555 South Section St., Fairhope, Alabama. One set of Bid Documents can be obtained free of charge. The bid packet is also available on the City of Fairhope Website: www.cofairhope.com.

1.05 INQUIRIES

Questions or comments pertaining to this bid must be presented in writing, sent as e-mail to the attention of the Purchasing Manager, Daniel P. Ames, P.O. Drawer 429, 555 South Section St., Fairhope, Al 36532, e-mail: dan.ames@cofairhope.com, Seventy Two (72) hours prior to the bid opening or will be forever waived.

1.06 SITE EXAMINATION / CITY PROVISION / NON-RESIDENT STATE BID RESIPROSCITY

Pre-bid conference to be held on site at Fairhope Recreation Department at 9:00 A.M. on Monday, August 13, 2012.

The City of Fairhope will not furnish any labor, material, or supplies unless specifically stated in the Contract Documents. Contractor must be properly licensed to perform the work as outlined in the Scope of Work. Bidder must have a current business license or purchase a business license with the City of Fairhope prior to bid being awarded. Where required by State Law, State Contractor's license is required.

Except for contracts funded in whole or in part by funds received from a federal agency, preference shall be given to resident contractors on the same basis as the nonresident bidder's state awards contract to Alabama contractors bidding under similar circumstances. Therefore, non-resident bidders shall submit with their bid a written opinion of an attorney at law licensed to practice law in the non-resident bidder's state of domicile as to preferences granted by that state to entities doing business in that state when letting public contracts.

1.07 BID SECURITY

Bids shall be accompanied by a Bid Security equal to 5% (percent) of the bid price, but in no event more than \$10,000.00. Bid Security shall be in the form of a Bid Bond or a cashier's check payable to The City of Fairhope. No Bid Security is required on bids less than \$10,000.00.

1.08 PERFORMANCE ASSURANCE AND INSURANCE

The bidder to whom award is made shall provide a Performance Bond equal to 100% of the Contract Amount and a Labor and Material Bond equal to 50% of the contract amount. The accepted Bidder shall also provide insurance as required in section 1.20.

1.09 DURATION OF OFFER

Bids may be withdrawn in written or telegraphic request received from bidder prior to the time fixed for opening. No bid shall be withdrawn for a period of thirty (30) days subsequent to the opening of bids without the consent of the City Council of the City of Fairhope.

1.10 EQUAL OPPORTUNITY

The City of Fairhope is an Equal Opportunity Employer and requires that all contractors comply with the Equal Employment Opportunity laws and the provisions of the Contract Documents in this regard. The City of Fairhope also encourages and supports the utilization of Minority Business Enterprises on this and all public bids.

1.11 BID SUBMISSION AND PREPARATION

Sealed Bids, signed, executed, and dated, will be received by The City of Fairhope as noted in section 1.03 above.

Submit one copy of the executed offer on the Bid Form provided, signed, and with the required Bid Security. The bid shall be enclosed in a sealed opaque envelope approximately 9x12 inches or larger, clearly identified on the outside as a **SEALED BID** with **PROJECT NAME, PROJECT NUMBER, OWNER'S NAME AND ADDRESS, BIDDER'S NAME AND ADDRESS, AND BIDDER'S CONTRACTOR'S LICENSE NUMBER, WHERE APPLICABLE.**

Forms furnished, or copies thereof, shall be used, and strict compliance with the requirements of the invitation, these instructions, and the instructions printed on the forms is necessary. Special care should be exercised in the preparation of bids. Bidders must make their own estimates of the facilities and difficulties attending the performance of the proposed contract, including local conditions, uncertainty of weather, and all other contingencies. All designations and prices shall be fully and clearly set forth. The proper spaces in the bid and guaranty forms shall be suitably filled in.

Fill in all blanks on the bid form with non-erasable ink or type. Erasers or other changes must be explained or noted over the signature of the bidder.

The Bid Form may have a Contingency Allowance listed. Add this amount to the Base Bid to derive the Total Bid. The Contingency Allowance covers unforeseen conditions and shall not be used by the Contractor without the written authorization of the City of Fairhope. At the conclusion of the project, the unused portion of the Contingency Allowance shall revert to the City of Fairhope.

Each bid must give the full business address of the bidder and must be signed by him with his usual signature. Bids by partnerships must furnish the full names of all partners and must be signed with the partnership name by one of the members of the partnership, or by an authorized representative, followed by the signature and designation of the person signing. Bids by corporations must be signed with the legal name of the corporation followed by the name of the State of Incorporation and by the signature and designation of the president, secretary, or other person authorized to bind it in the matter. The name of each person shall also be typed or printed below the signature. A bid by a person who affixes to this signature the word "president," "secretary," "agent," or other designation without disclosing his principal, may be held to be the bid of the individual signing. When requested by the City of Fairhope satisfactory evidence of the authority of the officer signing in behalf of the corporation shall be furnished.

Each project will be bid separately unless otherwise expressly requested in the contract document. Combination bids, that is, bids on separate projects lumped together as a single bid or on all or none basis, will not be accepted unless the contract document expressly requests or permits same.

Alternate bids will not be considered unless requested.

1.12 BID INELIGIBILITY

Bids that contain irregularities of any kind may be declared unacceptable at the discretion of the City. The City may waive any irregularities and may reject any or all bids. Bids received after the deadline will be returned to the bidder unopened.

1.13 CONTRACT TIME

The Contractor agrees to perform the work within the time stated in the Bid Form. The bidder in submitting an offer accepts the conditions of the contract period stated for performing the work.

1.14 CONSTRUCTION DOCUMENT IDENTIFICATION

The Construction Documents are the Bid Packet, any Drawings, Addenda, Amendments and all other related documents bearing the Project Title and Number.

Bidders shall use complete sets of Construction Documents in preparing their Bids. The City of Fairhope will not assume responsibility for errors or misinterpretation resulting from the use of incomplete sets of Construction Documents.

1.15 INQUIRIES/ADDENDA

Questions or comments pertaining to this bid must be presented in writing, sent as e-mail to the attention of the Purchasing Manager, Daniel P. Ames, P.O. Drawer 429, 555 South Section St., Fairhope, AL 36532, e-mail: dan.ames@cofairhope.com, Seventy Two (72) hours prior to the bid opening or will be forever waived.

All Addenda are part of the Contract Documents. Include resultant costs in the Bid. Addenda will be issued by posting to the City of Fairhope website: www.cofairhope.com, and posted on the City's bulletin board at 555 South Section St., Fairhope, AL. It is the responsibility of the bidder to obtain any addenda, and verify that all addenda have been received.

1.16 BID ACCEPTANCE

Bid with lowest Total Bid amount from a responsive and responsible bidder may be accepted if within the Contract Budget. In the event that alternates are listed on the Bid Form, the lowest combination of Total Bid and Alternate Bids accepted by the City shall be the accepted bid. Alternates shall be awarded in the order in which they are listed on the Bid Form.

1.17 BIDDERS INTERESTED IN MORE THAN ONE BID

If more than one bid is offered by any one party, by or in a name of his clerk, partner, corporation in which he has a substantial interest, or in which he is an officer, or other person, all such bids may be rejected. A party who has quoted prices on materials to a bidder is not thereby disqualified from quoting prices to other bidders or from submitting a bid directly for the materials or work. The City reserves the right to determine in its discretion whether the provisions of this clause have been violated by any bidder.

1.18 ERRORS IN BIDS

Bidders or their authorized agents are expected to examine the maps, drawings, specifications and all other instructions pertaining to the work, which will be open to their inspection. Failure to do so will be at the bidder's own risk. In case of error, in the extension of prices, the unit price will govern.

1.19 CONTRACT AND BOND

The bidder to whom award is made must, when requested, enter into written contract on the standard form as set out herein, with satisfactory security in the amount required, within the period specified, or, if no period is specified, within 15 days after the required forms are presented to him for signature.

INSURANCE REQUIREMENTS

1. Awarded bidder, at its sole expense, shall obtain and maintain in full force the following insurance to protect the awarded bidder and the City of Fairhope at limits and coverages specified herein. The City of Fairhope will be listed as “additionally insured” on all applicable policies and certificates of insurance. These limits and coverages specified are the minimum to be maintained and are not intended to represent the correct insurance needed to fully and adequately protect the awarded bidder.

2. All insurance will be provided by insurers by admitted carriers in the State of Alabama, shall have a minimum A.M. Best rating of A-VII and must be acceptable to the City. Self-insured plans and/or group funds not having an A.M. Best rating must be submitted to the City for prior approval.

3. NO WORK IS TO BE PERFORMED UNTIL PROOF OF COMPLIANCE WITH THE INSURANCE REQUIREMENTS HAS BEEN RECEIVED BY THE CITY.

4. Worker’s Compensation and Employers Liability

Part One: Statutory Benefits as required by the State of Alabama

Part Two: Employers Liability \$100,000 Each Accident
\$100,000 Each Employee
\$500,000 Policy Limit

5. U.S. Longshoreman & Harbor workers Act (USL&H)-

Required if contract involves work near a navigable Waterway that may be subject to the USL&H law.

6. Maritime Endorsement (Jones Act)-

Endorsement required if contract involves the use of a Vessel. Or include coverage for “Master or Members or Crew” under “Protection and Indemnity” coverage (P&I), unless crew is covered under Workers Compensation.

Bodily injury by accident \$1,000,000 Each Accident
Bodily injury by disease \$1,000,000 Aggregate

7. Commercial General Liability

Coverage on an Occurrence form with a combined single limit of (Bodily Injury and Property Damage combined as follows:

Each Occurrence \$1,000,000
Personal and Advertising Injury \$1,000,000
Products/Completed Operation Aggregate \$2,000,000
General Aggregate \$2,000,000

- Coverage to include

- o Premises and operations
- o Personal Injury and Advertising Injury

-

- o Products/Completed Operations
- o Independent Contractors
- o Blanket Contractual Liability
- o Explosion, Collapse and Underground hazards
- o Broad Form Property Damage
- o Railroad Protective Liability Insurance if work involves construction, demolition or maintenance operations on or within 50 feet of a railroad.

8. Automobile Liability

Covering all Owned, Non-Owned, and Hired vehicles with a limit of no less than \$1,000,000 combined single limit of Bodily Injury and property damage per occurrence.

9. Certificate of Insurance

A Certificate of Insurance evidencing the above minimum requirements must be provided to and accepted by the City **PRIOR** to commencement of any work on the contract. Each policy shall be endorsed to provide ten (10) days written notice of cancellation to the City.

1.21 COLLUSION

If there is any reason for believing that collusion exists among the Bidders any or all bids may be rejected, and those participating in such collusion may be barred from submitting bids on the same or other work with the City.

1.22 SUBLETTING OR ASSIGNING OF CONTRACT

Limitations: The Contractor shall not sublet, assign, transfer, convey, sell, or otherwise dispose of any portion of the contract, his right, title or interest therein, or his power to execute such contract, to any person, firm or corporation without written consent of the City, and such written consent shall not be construed to relieve the Contractor of any responsibility for the fulfillment of the contract. Unless otherwise stipulated in the proposal or special provisions, the Contractor shall perform with his own organization, and with the assistance of workmen under his immediate superintendence and reported on his payroll, all contract work of a value not less than 50 percent of the total contract amount, except that any items designated in the contract as "Specialty Items" so performed by subcontract may be deducted from the total contract amount before computing the amount of work required to be performed by the Contractor with his own organization.

Subcontractor's Status: A Subcontractor shall be recognized only in the capacity of an employee or agent of the Contractor and the Contractor will be responsible to the City for all of the subcontractor's work, including failures or omissions; and his removal may be required by the Project Manager, as in the case of an employee.

1.23 PROSECUTION OF WORK

The Contractor shall commence work within 10 days of issuance of the Notice to Proceed (NTP) or as otherwise directed in writing.

The Contractor shall prosecute the work continuously and diligently in the order and manner set out in his schedule as approved by the Project Manager. He shall provide sufficient satisfactory materials, labor, and equipment to insure that the work will be completed in a satisfactory manner within the time specified in the contract.

Should the Contractor fail to maintain a satisfactory rate of progress, the Project Manager may require that additional forces and/or equipment be placed on the work to bring the project up to schedule and maintain it at that level.

Should the Contractor fail to furnish sufficient satisfactory equipment and/or labor for maintaining the quality and progress of the work at satisfactory level, the Project Manager may withhold all estimates that may become due until satisfactory quality and progress are maintained; or the contract may be annulled.

ITEM II
BID FORM

Date: __/__/____

Bid No. **013-12**
Bid Name: **Baby Pool Renovations**
Project No. **PW004-12**
Project Name: **Baby Pool Renovations**

Base bid will include all labor, materials, equipment, shipping, overhead, profit, bonds, insurance and all other costs necessary to provide the complete services outlined within this contract and scope of work.

The owner agrees to provide the following materials: NONE

Base Bid \$ _____
Allowance \$ 5000.00 _____
Total Base Bid \$ _____

ALTERNATE: (7400 S.F. approximate area of concrete topping for remaining deck.)

(Actual quantities will be measured before installation.)

Quantity _____ S.F. Unit Price \$ _____/S.F. Total Bid w/ Alternate \$ _____

City of Fairhope will issue permit at no expense to contractor.

The contractor agrees to complete all the work within Sixty (60) working days from date given in the *Notice to Proceed* (NTP) unless other arrangements are approved by the Project Manager.

Receipt of the following Addenda to these documents is hereby acknowledged by the undersigned (bidder to complete below):

ADDENDUM NO.	DATE ISSUED	ADDENDUM NO.	DATE ISSUED
_____	_____	_____	_____
_____	_____	_____	_____

Each bid must give the full business address of the bidder and must be signed by him with his usual signature. Bids by partnerships must furnish the full names of all partners and must be signed with the partnership name by one of the members of the partnership, or by an authorized representative, followed by the signature and designation of the person signing. Bids by corporations must be signed with the legal name of the corporation followed by the name of the State of Incorporation and by the signature and designation of the president, secretary, or other person authorized to bind it in the matter. The name of each person shall also be typed or printed below the signature. A bid by a person who affixes to this signature the word "president," "secretary," "agent," or other designation without disclosing his principal, may be held to be the bid of the individual signing. When requested by the City of Fairhope, Baldwin County, Alabama, satisfactory evidence of the authority of the officer signing in behalf of the corporation shall be furnished. The undersigned agrees to furnish the goods/services as requested by you for the City of Fairhope, Baldwin County, Alabama in your invitation to bid, and certifies that they will meet or exceed the specifications called

for. The undersigned has read all information pertaining to this bid and has resolved all questions. It is also understood and agreed that all prices quoted are F.O.B. described in the bid documents and specifications. The undersigned also affirms he/she has not been in any agreement or collusion among bidders or prospective bidders in restraint of freedom of competition, by agreement to bid at a fixed price or to refrain from bidding or otherwise.

Witness our hands and seals this ____ day of _____, 20____

If Individual or Partnership

(Name of Individual or Partnership) (Name of Partner Print)

(Name of Representative Authorized to sign Bids and Contracts for the firm Print) (Name of Partner Print)

(Name of Representative Authorized to sign Bids and Contracts for the firm Signature)

(Address)

(Address)

(Address)

Phone Number () _____ Fax Number () _____

Primary e-mail address _____

Alabama Contractor's License No. _____

If Corporation or LLC

Company _____

State of Incorporation _____

Company Representative _____
(Representative Authorized to sign Bids and Contracts for the firm Print)

Company Representative _____
(Representative Authorized to sign Bids and Contracts for the firm Signature)

Address _____

Phone Number() _____ Fax Number(____) _____

Primary e-mail address _____

Alabama Contractor's License No. _____

CONTRACTOR'S STATE OF ALABAMA
FOREIGN VENDOR REGISTRATION NUMBER
(Required of out-of-state-vendors)

BID PROPOSAL NOTARIZATION:

STATE OF _____}

COUNTY OF _____}

I, the undersigned authority in and for said State and County, hereby certify that _____, as _____ respectively, of _____, whose name is signed to the foregoing document and who is known to me, acknowledged before me on this day, that, being informed of the contents of the document they executed the same voluntarily on the day the same bears date. Given under my hand and Notary Seal on this _____ day of _____, 2012

NOTARY PUBLIC

_____/_____/_____
MY COMMISSION EXPIRES:

PERFORMANCE BOND

KNOW ALL MEN: That we _____
(Insert here the name & address of legal title of the Contractor)

_____ hereinafter called the Principal, and

(Insert here the name and address of legal title of one or more sureties)

and
_____ and

_____ hereinafter called the Surety or Sureties, are held and firmly bound unto The City of Fairhope hereinafter called the Owner in the sum of _____ Dollars (\$_____) for the payment whereof the Principal and the Surety or Sureties bind themselves, their heirs, executors, administrators, successors and assigns, jointly and severally, firmly, by these presents.

WHEREAS, the Principal has, by means of a written agreement, dated __/__/____ entered into a contract with the Owner for: **Bid No. 013-12, Baby Pool Renovations, Project No. 004-12, Baby Pool Renovations**, which agreement is by reference made a part hereof,

NOW THEREFORE, The conditions of this obligation is such that if the Principal shall faithfully perform the Contract on his part, and satisfy all claims and demands, incurred for the same, and shall fully indemnify and save harmless the Owner from all cost and damage which he may suffer by reason of failure to do so, and shall reimburse and repay the Owner all outlay and expense which the Owner may incur in making good for any such default thence this obligation shall be null and void; otherwise, it shall remain in full force and effect.

PROVIDED, HOWEVER, that no suit, action or proceedings, by reason of any default whatever be brought on his Bond after twelve months from the day on which the final payment under the Contract falls due.

PROVIDED, further, that the said surety or sureties, for value received hereby stipulate and agree that no change, extension of time, or addition to the terms of the Contract or to the work to be performed thereunder of the Specifications thereof shall in any way effect their obligations on this bond, and they do hereby waive notice of any such change, extension of time, alteration or addition to the terms of the contract, or to the work, or to the Specifications.

Witness our hands and seals this ____ day of _____, 2012.

Individual

_____, Doing Business As, _____
(Signature of Individual Bidder) (Business Name)

Business Mailing Address: _____

Email _____

Corporation, Partnership, or Joint Venture

Name of Corporation, Partnership, or Joint Venture

Business Mailing Address: _____

Email _____

BY: _____
(Signature of Officer Authorized to sign Bids
and Contracts for the Firm)

(Position or Title)

(GENERAL CONTRACTOR'S LICENSE NUMBER)

**CONTRACTOR'S STATE OF ALABAMA
FOREIGN VENDOR REGISTRATION
NUMBER (Required of out-of-state-vendors)**

Attest:

(Secretary)

(Name of State under the laws of which incorporated)

(Name of Surety)

BY: _____
(Attorney in Fact)

LABOR AND MATERIALS BOND

KNOW ALL MEN BY THESE PRESENTS, that we _____ As Principal, and _____ as Surety, are held and firmly bound unto said City of Fairhope hereinafter called the Obligee, in the penal sum of _____ Dollars (\$ _____) lawful money of the United States, for the payment of which sum and truly to be made, we bind ourselves, our heirs, personal representatives, successors and assigns, jointly and severally, firmly by these presents.

WHEREAS, said principal has entered into a certain Contract with said Obligee, dated ____ day _____ 2012. (Hereinafter called the Contract) for **Bid No. 013-12, Baby Pool Renovations, Project No. 004-12, Baby Pool Renovations**, which Contract and the Specifications for said work shall be deemed a part hereof as fully as if set out herein.

NOW, THEREFORE, THE CONDITION OF THIS OBLIGATION IS SUCH THAT if the said Principal and all subcontractors to whom any portion of the work in said contract is sublet and all assignees of said Principal and of such subcontractors shall promptly make payments to all persons supplying him or them with labor, materials, or supplies for or in the prosecution of the work provided for in such Contract, or any amendment or extension of or addition to said Contract, and for the payment of reasonable attorney's fees incurred by the successful claimant or plaintiffs in suits or claims against the contractor arising out of or in connection with the said contract, then the above obligation shall be void; otherwise to remain in full force and effect.

PROVIDED, HOWEVER, that this bond is subject to the following conditions and limitations.

(a) Any person, firm or corporation that has furnished labor, materials, or supplies for or in the prosecution of the work provided for in said Contract shall have a direct right to action against the Principal and Surety on this bond, which right of action shall be asserted in a proceeding, instituted in the County in which the work provided for in said Contract is to be performed or in any County in which said Principal or Surety does business. Such right of action shall be asserted in a proceeding instituted in the name of the claimant or claimants for his or their use and benefit against the Principal and Surety or either of them (but not later than one year after the final settlement of said Contract falls due) in which action such claim or claims shall be adjusted and judgment rendered thereon.

(b) The Principal and Surety hereby designate and appoint the Mayor of the City of Fairhope or his successor or representative as the agent of each of them to receive and accept services of process or other pleading issued, or filed in any proceeding instituted on this bond and hereby consent that such service shall be the same as personal service on the Principal and/or Surety.

(c) The Surety shall not be liable hereunder for any damages or compensation recoverable under Workmen's Compensation or Employer's Liability Statute.

(d) In no event shall the Surety be liable for a greater sum than the penalty of this bond, or subject to any suit, action or proceeding thereon that is instituted later than one year after the final settlement of said contract.

(e) This Bond is given pursuant to the terms of an Act of the Legislature of the State of Alabama approved February 8, 1935, entitled: "An Act to further provide for Bonds and Contractors on State and other public works and suits thereon".

Witness our hands and seals this ____ day of _____, 2012.

Individual

_____, Doing Business As, _____
(Signature of Individual Bidder) (Business Name)

Business Mailing Address:

Email _____

Corporation, Partnership, or Joint Venture

Name of Corporation, Partnership, or Joint Venture

Business Mailing Address

Email _____

BY: _____
(Signature of Officer Authorized to sign Bids and Contracts for the Firm) (Position or Title)

Business Mailing Address:

Email: _____

(GENERAL CONTRACTOR'S LICENSE NUMBER)

CONTRACTOR'S STATE OF ALABAMA
FOREIGN VENDOR REGISTRATION
NUMBER (Required of out-of-state-vendors)

Attest:

(Secretary)

(Name of State under the laws of which incorporated)

(Name of Surety)

BY: _____
(Attorney in Fact)

ITEM IV

CERTIFICATE OF CONTRACTOR'S & SUBCONTRACTOR'S INSURANCE

FORM FOR CERTIFICATE OF CONTRACTORS AND SUBCONTRACTORS INSURANCE TO THE CITY OF FAIRHOPE, ALABAMA

Date _____

This is to certify that the policies designated below have been issued by the _____ and are in force on the date borne by this certificate.

1. Location and designation of project:

2. Name and address of insured for whom this certificate is issued:

3. Type of insurance:

Limits of Liability

(a) Workmen's Compensation:

_____	_____	_____	_____	_____
(policy number)	(exp. date)	(coverage)	(aggregate)	(one person)
			(one person)	(one accident)

(b) Contractor's Public Liability:

1. Bodily Injury:

_____	_____	_____
(each person)	(each occurrence)	(total coverage)

2. Property Damage:

_____	_____
(each accident)	(aggregate)

(c) Automobile (Motor Vehicle):

1. Bodily Injury:

_____	_____	_____
(Each Person)	(Each Occurrence)	(Total Coverage)

2. Property Damage:

_____	_____
(Each Accident)	(Aggregate)

(d) Owner's Protective Liability:

_____	_____
(Each Occurrence)	(Each Occurrence)

(Bodily Injury)

(Property Damage)

Such insurance as is afforded by the above policies covers the operations undertaken by the insured with respect to the construction of the project above designated. The insurance afforded by the above-designated policies, specimen copies of which have been filed with the City , and to each of which is attached for following endorsement.

The insurer agrees with the insured as follows:

1. That it will furnish to said City of Fairhope a certificate of insurance in triplicate on a form approved for such purpose by said City, setting forth the pertinent information regarding the policy to which this endorsement is attached, for each project of said City to which the policy applies.
2. That it will attach to each said certificate of insurance executed copies of any endorsement other than this endorsement which are attached to said policy at the time said policy is issued, provided only that said endorsements affect the coverage of said policy in respect of operations involved in the construction of the projects of said City to which the policy applies.
3. That it will mail to the City Council of the City of Fairhope three executed copies of each endorsement

subsequently issued to become a part of said policy provided only that endorsement affects the coverages of said policy in respect of operations involved in the construction of the project of said City which the policy applies, and provided further that such endorsement shall not be effective unless such notice is given to the City at the same time that notice thereof is given to the insured.

4. That it will mail to the City Council of the City of Fairhope at least ten days before the effective date thereof notice of cancellation of said policy, provided no cancellation shall be effective unless such notice is given to the City.

Insurer

BY: _____
Authorized Representative

**ITEM V
CONTRACT**

SAMPLE

This **CONTRACT** is made this ____ day of _____, 2012, by and between the City of Fairhope (hereinafter "**OWNER**") and _____ (hereinafter "**CONTRACTOR**"), on the

BID NO. 013-12 Baby Pool Renovations
PROJECT NO. PW004-12 Baby Pool Renovations

The **OWNER** and the **CONTRACTOR** agree as set forth below:

1. The contract consists of all of the items contained within this contract, the bid package, and if any, drawings, addenda and amendments, and "City of Fairhope Standard Terms and Conditions" (attached).
2. The **CONTRACTOR** shall perform all the **WORK** described herein.
3. The **WORK** to be performed under this **CONTRACT** shall be commenced upon execution of this **CONTRACT** within ten (10) days of the date specified in a *Notice to Proceed* (NTP) to be issued to the Contractor by the Owner, or its authorized representative. The work shall be completed, subject to authorized adjustments, within Sixty (60) working days from and after the commencement date stipulated in said *Notice to Proceed*. Liquidated damages for non-completion of the work within this time limit will be assessed at the rate of \$200 per working day.
4. The **OWNER** shall pay the **CONTRACTOR** in current funds for the performance of the **WORK**, the **CONTRACT SUM** of _____ (\$_____) as per "**Scope of Work**" attached. This represents a **LUMP SUM** payment for performance of the **WORK**, which payment shall be issued after the contract is fully performed and the **OWNER** has inspected the **WORK**. Upon completion of the work, the **OWNER** will cause notice of final completion of the **CONTRACT** to be published one (1) time in a newspaper of general circulation, published in **BALDWIN COUNTY** and shall post notice of final completion on its bulletin board for one (1) week, and the **CONTRACTOR** shall certify under oath that all bills have been paid in full. The parties may complete final settlement any time after the notice has been posted for an entire week.
5. The **CONTRACTOR** shall not commence work under this **CONTRACT** until it has purchased **INSURANCE** for protection from any and all claims that may arise out of or result from the **CONTRACTOR'S** operations under the **CONTRACT**. The **CONTRACTOR** shall maintain the required insurance in the minimum amounts as described in Item IV.
6. To the fullest extent permitted by law, the **CONTRACTOR** shall indemnify and hold harmless the **OWNER**, and its agents and employees from and against all claims, damages, losses and expenses, including, but not limited to, attorneys' fees arising out of or resulting from the performance of the **WORK**.
7. The **CONTRACTOR** has thoroughly and completely inspected the premises, and hereby agrees to perform the **WORK** for the **CONTRACT SUM**.
8. The **CONTRACTOR** warrants to the **OWNER** that all materials furnished under this **CONTRACT** will be new, and that all work will be of a good quality, free from faults and defects and in conformance with the **CONTRACT DOCUMENTS**. All **WORK** not conforming to these requirements, including substitutions not properly approved and authorized, may be considered defective. If required by the **OWNER**, the **CONTRACTOR** shall furnish satisfactory

evidence as to the kind and quality of materials.

9. The **CONTRACTOR** shall promptly correct all **WORK rejected** by the **OWNER** as defective or failing to conform to the **CONTRACT DOCUMENTS**. The **CONTRACTOR** shall bear all costs of correcting such rejected **WORK**, regardless of whether the **WORK** is fabricated, installed or completed.

10. The **CONTRACTOR** shall remove from the site all portions of the **WORK** which are defective or non-conforming and which have not been corrected, unless removal is waived by the **OWNER**.

11. If the **CONTRACTOR** fails to correct defective or nonconforming **WORK** within a reasonable time fixed by written notice from the **OWNER**, the **OWNER** may correct and the **CONTRACTOR** shall bear the cost of making good all work of the **OWNER** or separate contractors.

12. If the **OWNER** prefers to accept the defective or nonconforming **WORK**, the **OWNER** may do so instead of requiring its removal and correction, in which case a reduction in the **CONTRACT SUM** shall be effected whether or not final payment has been made. The reduction shall be equitable and appropriate.

13. If the **CONTRACTOR** fails to correct defective **WORK** as set forth above or persistently fails to carry out the **WORK** in accordance with the **CONTRACT DOCUMENTS**, or fails to supply enough properly trained workers or proper materials or disregards laws, ordinances, rules or regulations, the **OWNER**, by a written order signed by its authorized agent, may order the **CONTRACTOR** to stop the **WORK**. If the **CONTRACTOR** fails within the seven (7) days after receipt of written notice to commence corrective action, the **OWNER** may, after seven (7) days follow the receipt of an additional written notice, and without prejudice to any other remedy of the **OWNER**, terminate employment of the **CONTRACTOR** and take possession of the site and of all materials thereon, and may finish the work by whatever methods the **OWNER** finds expedient.

14. If, within one (1) year after acceptance of the **WORK** by the **OWNER**, or within such longer period of time as may be prescribed by law or by the terms of any applicable special warranty required by the **CONTRACT DOCUMENT**, any of the **WORK** is found to be defective or not in conformity with the **CONTRACT DOCUMENTS**, the **CONTRACTOR** shall correct it promptly after receipt of a written notice from the **OWNER** to do so unless the **OWNER** has previously given the **CONTRACTOR** a written acceptance of such condition. This obligation shall survive both final payment for the **WORK** and termination of the **CONTRACT**. The **OWNER** shall give such notice promptly after discovery of the condition.

15. If the **CONTRACTOR** is delayed at any time in the progress of the **WORK** by any act or neglect of the **OWNER**, any of its employees, labor disputes, fire, unusual delay in transportation, adverse weather conditions not reasonably anticipatable, unavoidable casualties, or any causes beyond the **CONTRACTOR'S** control, the **CONTRACT** time shall be extended to such reasonable time as the **OWNER** may determine.

16. The **CONTRACTOR** shall be responsible for initiating, maintaining and supervising all safety precautions and programs in connection with the **WORK**. The **CONTRACTOR** shall perform the **WORK** in a manner that allows the **OWNER** to the maximum extent possible to continue its daily operations on the premises.

17. The **CONTRACTOR** shall at all times keep the premises free from accumulation of waste materials or rubbish caused by the **CONTRACTOR'S** operations. At the completion of the **WORK**, the **CONTRACTOR** shall remove all the **CONTRACTOR'S** waste materials and rubbish from and about the **PROJECT** as well as all the **CONTRACTOR'S** tools, construction equipment, machinery and surplus materials. If the **CONTRACTOR** fails to clean up at the completion of the **WORK**, the **OWNER** may do so and the cost thereof shall be charged to the **CONTRACTOR**.

18. **WRITTEN NOTICE** shall be deemed to have been duly served if delivered in person to the individual or member of the firm or entity or to an officer of the corporation for whom it was intended, or if delivered at or sent by registered or certified mail to the last business address known to the party giving the notice.

19. The duties and obligations imposed by the **CONTRACT DOCUMENTS** and the **RIGHTS AND REMEDIES** available there under shall be in addition to, and not a limitation of, any duties, obligations, rights and remedies otherwise imposed or available by law.

20. Should either party to the **CONTRACT** suffer injury or damage to person or property because of any act or omission of the other party or of any of the other party's employees or agents, claim shall be made in writing to such other party within a reasonable time after the first observance of such injury or damage.

21. The **OWNER** and **CONTRACTOR**, respectively, bind themselves, their partners, successors, assigns and legal representatives to the other party hereto and to the partners, successors, assign and legal representatives of such other party with respect to all covenants, agreements and obligations contained in the **CONTRACT DOCUMENTS**. Neither party to the **CONTRACT** shall assign the **CONTRACT** or sublet it as a whole without the written consent of the other.

IN WITNESS WHEREOF, the parties hereto have executed this Contract as of the day and year first above written.

SIGNATURES FOR THE CITY OF FAIRHOPE

FAIRHOPE

BY: _____

ATTEST: _____

TIMOTHY M. KANT, Mayor

LISA A. HANKS, City Clerk

NOTARIZATION FOR THE CITY:

STATE OF ALABAMA]

COUNTY OF BALDWIN]

I, _____, a Notary Public in and for said State and County, hereby certify that Timothy M. Kant, whose names as Mayor of the City of Fairhope, is signed to the foregoing conveyance and who is known to me, acknowledged before me on this day, that, being informed of the contents of the conveyance, he as such officer and with full authority, executed the same voluntarily on the day the same bears date.

Given under my hand and Notary seal on this the ____ day of _____ 2012

Notary
My commission expires ___/___/___

CONTRACTOR

Individual or Partnership

(Individual or Partnership)

(Name of Partner Print)

(Representative Authorized to sign Bids and
Contracts for the firm Print)

(Name of Partner Print)

(Name of Representative Authorized to sign Bids and
Contracts for the firm Signature)

(Address)

(Address)

(Address)

Phone Number () _____ Fax Number () _____

Primary e-mail address _____

Alabama Contractor's License No. (If required) _____

Foreign Corporation Registration _____
(Outside Alabama)

If Corporation or LLC

Company _____

State of Incorporation _____

Company Representative _____
(Name of Representative Authorized to sign Bids and Contracts for the firm Print)

Company Representative _____
(Name of Representative Authorized to sign Bids and Contracts for the firm Signature)

Address _____

Phone Number () _____ Fax Number() _____

Primary e-mail address _____

Alabama Contractor's License No. (If Required) _____

Foreign Corporation Registration _____
(Required of out-of-state-vendors)

Notary for Individual or Corporation or Contractor

STATE OF _____ }

COUNTY OF _____ }

I, the undersigned authority in and for said State and County, hereby certify that _____ ,
as _____ respectively, of _____
title _____ company name

whose name is signed to the foregoing document and who is known to me, acknowledged before me on this day, that,
being informed of the contents of the document they executed the same voluntarily on the day the same bears date.

Given under my hand and Notary Seal on this ___ day of _____, 2012

Notary Public
My commission expires ___/___/___

**ITEM VI
SCOPE OF WORK
TABLE OF CONTENTS**

DIVISION 01- GENERAL REQUIREMENTS (OWNER-FURNISHED SPECS.)

01100	SUMMARY
01300	ADMINISTRATIVE REQUIREMENTS
01330	SUBMITTAL PROCEDURES
01400	QUALITY REQUIREMENTS
01600	PRODUCT REQUIREMENTS

DIVISION 02- EXISTING CONDITIONS

02316	FILL AND BACKFILL
024119	SELECTIVE STRUCTURE DEMOLITION

DIVISION 03- CONCRETE

033000	CAST-IN-PLACE CONCRETE
03530	CONCRETE TOPPING

DIVISION 07- THERMAL AND MOISTURE PROTECTION

079200	JOINT SEALANTS
--------	----------------

DIVISION 09- FINISHES

093000	SWIMMING POOL TILE
099726	SWIMMING POOL PLASTER
09986	EXPOSED AGGREGATE POOL FINISH

DIVISION 22- PLUMBING

224000	PLUMBING FIXTURES
--------	-------------------

DIVISION 31- EARTHWORK

312323.33	FLOWABLE FILL
-----------	---------------

**SECTION 02316
FILL AND BACKFILL**

1.01 SECTION INCLUDES

- A. Filling, backfilling, and compacting for building volume below grade.
- B. Backfilling and compacting for utilities outside the building five (5) feet outside building.

1.02 RELATED REQUIREMENTS

- A. Section 31 2323.33 - Flowable Fill
- B. Section 03300 - Cast-in-Place Concrete

1.03 SUBMITTALS

- A. See Section 01300 - Administrative Requirements, for submittal procedures.
- B. Compaction Density Test Reports.

PART 2 PRODUCTS

2.01 FILL MATERIALS

- A. General Fill: Subsoil excavated on-site.
 - 1. Free of lumps larger than 3 inches, rocks larger than 2 inches, and debris.
 - 2. Conforming to ASTM D 2487 Group Symbol CL.
- B. Structural Fill: Flowable Fill

PART 3 EXECUTION

3.01 EXAMINATION

- A. Identify required lines, levels, contours, and datum locations.
- B. Verify dampproofing, or waterproofing installation has been inspected.

3.02 PREPARATION

- A. Scarify subgrade surface to a depth of 6 inches to identify soft spots.
- B. Cut out soft areas of subgrade not capable of compaction in place. Backfill with general fill material.
- C. Compact subgrade to density equal to or greater than requirements for subsequent fill material.
- D. Until ready to fill, maintain excavations and prevent loose soil from falling into excavation.

3.03 FILLING

- A. Fill to contours and elevations indicated using unfrozen materials.
- B. Fill up to subgrade elevations unless otherwise indicated.
- C. Employ a placement method that does not disturb or damage other work.
- D. Systematically fill to allow maximum time for natural settlement. Do not fill over porous, wet, frozen or spongy subgrade surfaces.
- E. Maintain optimum moisture content of fill materials to attain required compaction density.
- F. Soil Fill: Place and compact material in equal continuous layers not exceeding 8 inches compacted depth.
- G. Slope grade away from building minimum 2 inches in 10 ft, unless noted otherwise. Make gradual 090911 / AC Warner Pool 02316 - 1 FILL AND BACKFILL grade changes. Blend slope into level areas.
- H. Correct areas that are over-excavated.
 - 1. Load-bearing foundation surfaces: Use structural fill, flush to required elevation, compacted to 100 percent of maximum dry density.
- I. Compaction Density Unless Otherwise Specified or Indicated:
 - 1. Under paving, slabs-on-grade, and similar construction: 97 percent of maximum dry density.
 - 2. At footings: 95 percent of maximum dry density.
- J. Reshape and re-compact fills subjected to vehicular traffic.

3.04 FILL AT SPECIFIC LOCATIONS

- A. Under Interior Slabs-On-Grade:
 - 1. Use granular fill.
 - 2. Depth: 4 inches deep.
 - 3. Compact to 95 percent of maximum dry density.
 - 4. Cover with sand.
 - a. Depth: 2 inches.
 - b. Compact to 95 percent of maximum dry density.
- B. At Foundation Walls and Footings:
 - 1. Use structural fill.
 - 2. Do not backfill against unsupported foundation walls.
- C. Over Buried Utility Piping, Conduits, and Duct Bank:
 - 1. Bedding: Use general fill.
 - 2. Cover with general fill.
 - 3. Fill up to subgrade elevation.
 - 4. Compact in maximum 8 inch lifts to 95 percent of maximum dry density.

3.05 FIELD QUALITY CONTROL

A. See Section 01400 (014000) - Quality Requirements, for general requirements for field inspection and testing.

B. Perform compaction density testing on compacted fill in accordance with ASTM D1556, ASTM D2167, ASTM D2922, or ASTM D3017.

C. Evaluate results in relation to compaction curve determined by testing uncompacted material in accordance with ASTM D 698 ("standard Proctor"), ASTM D 1557 ("modified Proctor"), or AASHTOT 180.

D. If tests indicate work does not meet specified requirements, remove work, replace and retest.

E. Frequency of Tests: 500 yards.

F. Proof roll compacted fill at surfaces that will be under slabs-on-grade.

3.06 CLEANING

A. Remove unused stockpiled materials, leave area in a clean and neat condition. Grade stockpile area to prevent standing surface water.

END OF SECTION

SECTION 03530 CONCRETE TOPPING

PART 1 GENERAL

1.1 SECTION INCLUDES

- A. Concrete topping.

1.2 RELATED SECTIONS

- A. Section 03300 – Cast-in-Place Concrete.

1.3 REFERENCES

- A. ASTM C 666/C 666M – Standard Test Method for Resistance of Concrete to Rapid Freezing and Thawing.
- B. ASTM C 109/C 109M – Standard Test Method for Compressive Strength of Hydraulic Cement Mortars (Using 2-in. or [50-mm] Cube Specimens).
- C. ASTM C 944 – Standard Test Method for Abrasion Resistance of Concrete or Mortar Surfaces by the Rotating-Cutter Method.
- D. ASTM E 303 – Standard Test Method for Measuring Surface Frictional Properties Using the British Pendulum Tester.

1.4 SUBMITTALS

- A. Comply with Section 01330 – Submittal Procedures.
- B. Product Data: Submit manufacturer's product data, including surface preparation and application instructions.
- C. Samples: Submit manufacturer's standard color chart for selection of color.
- D. Certificate of Compliance: Submit manufacturer's certificate of compliance indicating materials comply with specified requirements.
- E. Applicator's Project References: Submit applicator's list of successfully completed concrete topping projects, including project name and location, name of architect, and type and quantity of materials applied.
- F. Maintenance Instructions: Submit manufacturer's maintenance and cleaning instructions.
- G. Warranty: Submit manufacturer's standard warranty.

1.5 QUALITY ASSURANCE

- A. Applicator's Qualifications:
 - 1. Applicator regularly engaged, for preceding 5 years, in application of concrete topping of similar type to that specified.
 - 2. Employ persons trained for application of concrete topping.
- B. Pre-installation Meeting:
 - 1. Convene pre-installation meeting before start of installation of concrete topping.
 - 2. Require attendance of parties directly affecting work of this section, including Owner, Contractor, Architect, installer and manufacturer's representative.
 - 3. Review preparation, mixing, installation, protection, and coordination with other work.

1.6 DELIVERY, STORAGE, AND HANDLING

- A. Delivery: Deliver materials to site in manufacturer's original, unopened containers and packaging, with labels clearly identifying product name and manufacturer.
- B. Storage:
 - 1. Store materials in clean, dry area indoors in accordance with manufacturer's instructions.

2. Keep containers sealed until ready for use.

C. Handling: Protect materials during handling and application to prevent contamination or damage.

1.7 ENVIRONMENTAL REQUIREMENTS

A. Placing Base Slab Concrete in Hot or Cold Weather. As specified in Section 03300 and in accordance with concrete topping manufacturer's instructions.

PART 2 PRODUCTS

2.1 MANUFACTURER

A. Mortex Manufacturing company, Inc., 1818 West Price Street, Tuscon, Arizona 85705. Toll Free (800) 338-3225. Phone (520) 887-2631. Fax (520) 293-8884. Website www.mortex.com. E-mail: office@mortex.com. (or approved equal.)

2.2 MATERIALS

A. Concrete Topping: "Kool Deck Elite" or approved equal.

1. Description: Powdered concentrate that when mixed properly with water and a Color-Unit pack forms a non-skid, weather resistant, colored, cementitious concrete topping.

a. Compressive Strength, ASTM C 109, Maximum Flow:

1) 7 Days: 1300 psi.

2) 14 Days: 1800 psi.

3) 28 Days: 2800 psi (30.0 MPa).

b. Rapid Freezing and Thawing, ASTM C 666: Beginning of failure of flat areas after 70 cycles.

c. Abrasion Resistance, ASTM C944:

1) Maximum Loss, 2-gram load, with 50 percent flat texture: 1 gram.

2) Maximum Loss, 6-gram load, with 50 percent flat texture: 3 grams.

d. Surface Friction, ASTM E 303: 69 average.

2. Color: Submit Color Options.

2.3 ACCESSORIES

A. 1 Color-Unit Pack per bag of Kool Deck Elite or approved equal.

B. Water: potable.

C. Bonding Agent: Mortex "PTA" bonding agent or approved equal.

PART 3 EXECUTION

3.1 EXAMINATION

A. Examine areas to receive base slab concrete and concrete topping.

B. Notify Engineer of conditions that would adversely affect application.

D. Do not begin surface preparation or application until unacceptable conditions are corrected.

3.2 SURFACE PREPARATION

A. Protection: Protect adjacent areas, adjoining walls, and landscaping from contact with concrete topping.

B. Base Slab Concrete: Place base slab concrete as specified in Section 03300, unless otherwise specified in this section.

1. Admixtures:

a. Use only admixtures approved by concrete topping manufacturer.

b. Do not use calcium chloride or admixtures containing chloride ions.

- c. Do not use fibers containing iron.
2. Do not begin finishing of base slab concrete until bleed water has left surface.
3. Scarify surface of base slab concrete surface with one pass of broom behind finish troweling.
4. Ensure finish of base slab concrete surface is in accordance with manufacturer's instructions for bonding to concrete topping.

3.3 MIXING

- A. Mix materials for concrete topping in accordance with manufacturer's instructions.
- B. Concrete topping materials:
 1. Proportion the following materials in accordance with manufacturer's instructions:
 - a. "Kool Deck Elite" or approved equal.
 - b. Color unit.
 - c. Water.
 2. Do not add other materials to mixture.
- C. Mix materials to ensure a uniform color blend.
- D. Test for correct consistency of concrete topping mixture with Mortex Viscosity Cup in accordance with manufacturer's instructions.

3.4 INSTALLATION

- A. Install concrete topping to base slab concrete in accordance with manufacturer's instructions at locations indicated on the drawings.
- B. Install concrete topping on same day as placement of base slab concrete.
- C. Install concrete topping 30 days after placement of base slab concrete. Bond concrete topping to base slab concrete with bonding agent applied in accordance with manufacturer's instructions.
- D. Concrete topping thickness: 1/8 inch.
- E. Trowel concrete topping in accordance with manufacturer's instructions.
- F. Ensure uniform color and texture of concrete topping.
- G. Do not apply curing compounds to concrete topping.

3.5 PROTECTION

- A. Protect completed concrete topping from contact for 48 hours after installation.
- C. Allow only light pedestrian traffic on completed concrete topping:
 1. Starting 48 hours after installation.
 2. Ending 14 days after installation.
- C. Protect completed concrete topping from damage during construction.

END OF SECTION

SECTION 014000
QUALITY REQUIREMENTS

PART 1 - GENERAL

1.1 SECTION REQUIREMENTS

- A. Testing and inspecting services are required to verify compliance with requirements specified or indicated. These services do not relieve Contractor of responsibility for compliance with the Contract Document requirements.
1. Testing and inspecting services are specified in other Sections of these Specifications or are required by authorities having jurisdiction and shall be performed by independent testing agencies.
 2. Where quality-control services are indicated as Contractor's responsibility, engage a qualified testing agency to perform these services.
 3. Contractor is responsible for scheduling times for tests, inspections, and obtaining samples and notifying testing agency.
 4. Retesting and Reinspecting: Contractor shall pay for additional testing and inspecting required as a result of tests and inspections indicating noncompliance with requirements.
- B. Submittals: Testing agency shall submit a certified written report of each test and inspection to Contractor, Owner, Engineer, and to authorities having jurisdiction when they so direct. Reports of each inspection, test, or similar service shall include the following:
1. Name, address, and telephone number of testing agency.
 2. Project title and number.
 3. Date of issue.
 4. Dates and locations of samples and tests or inspections.
 5. Record of temperature and weather conditions at time of sample taking and testing and inspecting.
 6. Names of individuals making tests and inspections.
 7. Description of the Work and test and inspection method.
 8. Complete test or inspection data, test and inspection results, an interpretation of test results, and comments or professional opinion on whether tested or inspected Work complies with the Contract Document requirements.
 9. Recommendations on retesting and reinspecting.
 10. Name and signature of laboratory inspector.
- C. Testing Agency Qualifications: An independent agency with the experience and capability to conduct testing and inspecting indicated; and where required by authorities having jurisdiction, that is acceptable to authorities.
- D. Testing Agency Responsibilities: Testing agency shall cooperate with Engineer and Contractor in performing its duties and shall provide qualified personnel to perform inspections and tests.

1. Agency shall promptly notify Owner, Engineer and Contractor of irregularities or deficiencies in the Work observed during performance of its services.
 2. Agency shall not release, revoke, alter, or increase requirements of the Contract Documents nor approve or accept any portion of the Work.
 3. Agency shall not perform any duties of Contractor.
- E. Auxiliary Services: Cooperate with testing agencies and provide auxiliary services as requested, including the following:
1. Access to the Work.
 2. Incidental labor and facilities necessary to facilitate tests and inspections.
 3. Adequate quantities of materials for testing, and assistance in obtaining samples.
 4. Facilities for storage and field curing of test samples.
 5. Security and protection for samples and for testing and inspecting equipment.
- F. Special Tests and Inspections: Owner will engage a qualified testing agency to conduct special tests and inspections required by authorities having jurisdiction.
- G. Special Tests and Inspections: Conducted by a qualified testing agency as required by authorities having jurisdiction, as indicated in individual Specification Sections.
- H. Minimum Quantity or Quality Levels: The quantity or quality level shown or specified shall be the minimum provided or performed. The actual installation may comply exactly with the minimum quantity or quality specified, or it may exceed the minimum within reasonable limits.

PRODUCTS (Not Applicable)

EXECUTION (Not Applicable)

END OF SECTION 014000

SECTION 016000
PRODUCT REQUIREMENTS

PART 1 - GENERAL

1.1 SECTION REQUIREMENTS

- A. The term "product" includes the terms "material," "equipment," "system," and terms of similar intent.
- B. Product Substitutions: Substitutions include changes in products, materials, equipment, and methods of construction from those required by the Contract Documents and presented by Contractor in the Bid Response.
 - 1. Submit 3 copies of each request for product substitution.
 - 2. Submit requests in the Bid Response.
 - 3. Do not submit unapproved substitutions on Shop Drawings or other submittals.
 - 4. Identify product to be replaced and show compliance with requirements for substitutions. Include a detailed comparison of significant qualities of proposed substitution with those of the Work specified and a list of changes needed to other parts of the Work required to accommodate proposed substitution.
 - 5. Engineer will review the proposed substitution in the Bid Response and will notify the Owner of substitution approval or rejection.
- C. Comparable Product Requests:
 - 1. Submit 3 copies of each request for comparable product. Do not submit unapproved products on Shop Drawings or other submittals.
 - 2. Identify product to be replaced and show compliance with requirements for comparable product requests. Include a detailed comparison of significant qualities of proposed substitution with those of the Work specified.
 - 3. Engineer will review the proposed product and notify Contractor of its acceptance or rejection.
- D. Deliver, store, and handle products using means and methods that will prevent damage, deterioration, and loss, including theft. Comply with manufacturer's written instructions.
 - 1. Schedule delivery to minimize long-term storage at Project site and to prevent overcrowding of construction spaces.
 - 2. Deliver products to Project site in manufacturer's original sealed container or packaging, complete with labels and instructions for handling, storing, unpacking, protecting, and installing.
 - 3. Inspect products on delivery to ensure compliance with the Contract Documents and to ensure that products are undamaged and properly protected.
 - 4. Store materials in a manner that will not endanger Project structure.
 - 5. Store products that are subject to damage by the elements, under cover in a weather tight enclosure above ground, with ventilation adequate to prevent condensation.
- E. Warranties specified in other Sections shall be in addition to, and run concurrent with, other warranties required by the Contract Documents. Manufacturer's disclaimers and limitations on product warranties do not relieve Contractor of obligations under requirements of the Contract Documents.

PART 2-PRODUCTS

2.1 PRODUCT OPTIONS

- A. Provide products that comply with the Contract Documents, are undamaged, and are new at the time of installation.
 - 1. Provide products complete with accessories, trim, finish, and other devices and components needed for a complete installation and the intended use and effect.
 - 2. Descriptive, performance, and reference standard requirements in the Specifications establish "salient characteristics" of products.
- B. Product Selection Procedures:
 - 1. Where Specifications name products or manufacturers, provide the item indicated or an approved equal that complies with requirements.
- C. Unless otherwise indicated, Owner will select color, pattern, and texture of each product from manufacturer's full range of options that includes both standard and premium items.

PART 3 - EXECUTION (Not Applicable)

END OF SECTION 016000

SECTION 024119
SELECTIVE STRUCTURE DEMOLITION

PART 1 – GENERAL

1.1 SECTION REQUIREMENTS

- A. Items indicated to be removed and salvaged remain Owner's property. Remove, clean, and deliver to Owner's designated storage area.
- B. Comply with EPA regulations and hauling and disposal regulations of authorities having jurisdiction.
- C. Owner will occupy portions of building immediately adjacent to selective demolition area. Conduct selective demolition so Owner's operations will not be disrupted.
- D. It is not expected that hazardous materials will be encountered in the Work. If materials suspected of containing hazardous materials are encountered, do not disturb; immediately notify Engineer and Owner.

PART 2 - PRODUCTS (Not Applicable)

PART 3 - EXECUTION

3.1 DEMOLITION

- A. Maintain services/systems indicated to remain and protect them against damage during selective demolition operations. Before proceeding with demolition, provide temporary services/systems that bypass area of selective demolition and that maintain continuity of services/systems to other parts of the building.
- B. Locate, identify, shut off, disconnect, and cap off utility services and mechanical/electrical systems serving areas to be selectively demolished.
- C. Provide temporary barricades and other protection required to prevent injury to people and damage to adjacent buildings and facilities to remain.
- D. Protect walls, ceilings, floors, and other existing finish work that are to remain. Erect and maintain dustproof partitions. Cover and protect furniture, furnishings, and equipment that have not been removed.
- E. Neatly cut openings and holes plumb, square, and true to dimensions required. Use cutting methods least likely to damage construction to remain or adjoining construction.
- F. Promptly remove demolished materials from Owner's property and legally dispose of them. Do not burn demolished materials.

END OF SECTION 024119

SECTION 033000
CAST-IN-PLACE CONCRETE

PART 1 - GENERAL

1.1 SECTION REQUIREMENTS

- A. Submittals: GENERAL Product Data, concrete mix designs and submittals required by ACI 301.
- B. Ready-Mixed Concrete Producer Qualifications: ASTM C 94/C 94M.
- C. Comply with ACI 301, "Specification for Structural Concrete"; ACI 117, "Specifications for Tolerances for Concrete Construction and Materials"; and CRSI's "Manual of Standard Practice."

PART 2 - PRODUCTS

2.1 MATERIALS

- A. Portland Cement: ASTM C 150, Type I or II.
- B. Fly Ash: ASTM C 618, Type C or F.
- C. Aggregates: ASTM C 33, uniformly graded.
- D. Air-Entraining Admixture: ASTM C 260.

2.2 MIXES

- A. Comply with ACI 301 requirements for concrete mixtures.
- B. Normal-Weight Concrete: Prepare design mixes, proportioned according to ACI 301, as follows:
 - 1. Minimum Compressive Strength: 3500 psi (24.1 MPa) at 28 days.
 - 2. Maximum Water-Cementitious Materials Ratio: **0.45**.
 - 3. Slump Limit: 4 inches (100 mm), plus or minus 1 inch (25 mm).
 - 4. Air Content: Maintain within range permitted by ACI 301. Do not allow air content of floor slabs to receive troweled finishes to exceed 3 percent.C.
- D. Measure, batch, mix, and deliver concrete according to ASTM C 94/C 94M and ASTM C 1116.
 - 1. When air temperature is above 90 deg F (32 deg C), reduce mixing and delivery time to 60 minutes.

PART 3 – EXECUTION

3.1 CONCRETING

- A. Construct formwork according to ACI 301 and maintain tolerances and surface irregularities within ACI 347R limits of Class A, 1/8 inch (3.2 mm).
- B. Install construction, isolation, and contraction joints where indicated.

- C. Place concrete in a continuous operation and consolidate using mechanical vibrating equipment.
- D. Protect concrete from physical damage, premature drying, and reduced strength due to hot or cold weather during mixing, placing, and curing.
- E. Formed Surface Finish: Smooth-formed finish for concrete exposed to view, coated, or covered by waterproofing or other direct-applied material; rough-formed finish elsewhere.
- F. Slab Finishes: Comply with ACI 302.1R for screeding, restraightening, and finishing operations for concrete surfaces. Do not wet concrete surfaces. Provide the following finishes:
 - 1. Troweled finish for floor surfaces and floors to receive floor coverings, paint, or other thin film-finish coatings.
- G. Cure formed surfaces by moist curing for at least seven days.
- H. Begin curing concrete slabs after finishing. Keep concrete continuously moist for at least seven days.
- I. Owner will engage a testing agency to perform field tests and to submit test reports.
- J. Protect concrete from damage. Repair surface defects in formed concrete and slabs.

END OF SECTION 033000

SECTION 079200
JOINT SEALANTS

PART 1 - GENERAL

1.1 SECTION REQUIREMENTS

- A. Submittals: Product Data and color Samples.
- B. Environmental Limitations: Do not proceed with installation of joint sealants when ambient and substrate temperature conditions are outside limits permitted by joint sealant manufacturer or are below 40 deg F.

PART 2 - PRODUCTS

2.1 JOINT SEALANTS

- A. Compatibility: Provide joint sealants, joint fillers, and other related materials that are compatible with one another and with joint substrates under service and application conditions.
- B. Sealant for Exterior Traffic-Bearing Joints, Where Slope Allows Use of Pourable Sealant:
 - 1. Single-component, pourable urethane sealant, ASTM C 920, Type S; Grade P; Class 25; Uses T, M, G, A, and O.

2.2 JOINT-SEALANT BACKING

- A. General: Provide sealant backings of material and type that are nonstaining; are compatible with joint substrates, sealants, primers, and other joint fillers; and are approved for applications indicated by sealant manufacturer.
- B. Cylindrical Sealant Backings: ASTM C 1330, of size and density to control sealant depth and otherwise contribute to producing optimum sealant performance.

PART 3 - EXECUTION

3.1 INSTALLATION

- A. Comply with ASTM C 1193.
- B. Comply with ASTM C 919 for use of joint sealants in acoustical applications.

END OF SECTION 079200

SECTION 093000
SWIMMING POOL TILE

PART 1 - GENERAL

1.1 SUMMARY

- A. Section includes ceramic tile for floor and wall applications; cementitious backer board as tile substrate; thresholds at door openings; and ceramic accessories.
- B. Related Sections:
 - 1. Section 03300- Cast-In-Place Concrete: Troweling of floor slab for tile applicaton.
 - 2. Section 07900- Joint Sealers.

1.2 SUBMITTALS

- A. Section 01330- Submittal Procedures: Submittal procedures.
- B. Shop Drawings: Indicate tile layout, patterns, colors arrangement, perimeter conditions, junctions with dissimilar materials, control and expansion joints, thresholds, ceramic accessories, and setting details.
- C. Product Data: Submit instructions for using grouts and adhesives.
- D. Samples: Submit mounted tile and grout on two plywood panels, 12 x 12 inch in size illustrating pattern, color variations, and grout joint size variations:
- E. Manufacturer's Certificate: Certify Products meet or exceed specified requirements.

1.3 CLOSEOUT SUBMITTALS

- A. Section 01700- Execution Requirements: Closeout procedures.
- B. Operation and Maintenance Data: Submit recommended cleaning methods, cleaning materials, stain removal methods, and polishes and waxes.

PART 2 - PRODUCTS

2.1 CERAMIC TILE

- A. Ceramic tile that complies with Standard grade requirements in ANSI A137.1, "Specifications for Ceramic Tile."
- B. Glazed Wall Tile: Flat tile

1. Products: National Pool Tile 6x6 Solids Pool Tile or approved equal.

Module Size: 6 by 6 inches (152.4 by 152.4 mm)

2. Color: (Navy) TBD
3. Finish: Glossy glaze.
4. Tiles mounted, by manufacturer's standard method, into sheets and grouted with silicone rubber grout complying with ANSI A118.6.

- C. Trim Units: Provide tile trim units to match characteristics of adjoining flat tile and to comply with following requirements:

1. Size: As shown, coordinated with sizes and coursing of adjoining flat tile where applicable.
2. Shapes: As follows, selected from manufacturer's standard shapes:
 - a. Base for Thinset Mortar Installations: Coved.
 - b. Wainscot Cap for Thinset Mortar Installations: Surface bullnose.
 - c. External Corners for Thinset Installations: Stretcher cap.
 - d. Internal Corners: Stretcher cove.

- D. Depth Marker Tile: Provide 4 inch high vertical depth markers on the wall just above the water line and on the deck in 1 inch x 1 inch tiles.

2.2 TILE MATERIALS

- A. Standard grade conforming to ANSI 137.1. Provide trimmer units as indicated and specified, including special shapes as detailed or required. Tile patterns and colors shall be as indicated and specified, colors of approved shades. Mesh mounted or perforated paper backed tile is not allowed where the mesh of paper remains as a permanent part of the installation.
- B. VOC Limit for Adhesives and Fluid-Applied Waterproofing Membranes: 65 g/L when calculated according to 40 CFR 59, Subpart D (EPA Method 24).
- C. Waterproofing Membranes for Thin-Set Installations: ANSI A118.10, unreinforced liquid-latex product and as follows:
- a. Products:
 - 1.) GreenSeel Liquid Applied Membrane or approved equal.
- D. Setting and Grouting Materials: Comply with material standards in ANSI's "Specifications for the Installation of Ceramic Tile" that apply to materials and methods indicated.
1. Thin-Set Mortar Type: Latex- portland cement.
 - a. Products:
 - 1) ARDEX X9 Premium ShearFlex Thin Set Mortar or approved equal.
 2. Grout Type: Polymer modified, Water-cleanable epoxy unless otherwise indicated.

Products:

1)ARDEX FLEX SANDED GROUT or approved equal.

3. Grout Color: White

PART 3 - EXECUTION

3.1 INSTALLATION

- A. Comply with tile installation standards in ANSI's "Specifications for the Installation of Ceramic Tile" that apply to materials and methods indicated.
 - 1. For installations indicated below, follow procedures in ANSI's "Specifications for the Installation of Ceramic Tile" for providing 95 percent mortar coverage.
- B. Comply with TCA's "Handbook for Ceramic Tile Installation."C.
- C. Wall Tile Installation Method(s):
Over Cementitious Backer Units: TCA W244 (thin-set mortar on cementitious backer units).
- D. Lay tile in grid pattern, unless otherwise indicated. Align joints where adjoining tiles on floor, base, walls, and trim are the same size.
- E. Perform cutting and drilling of tile without marring visible surfaces. Carefully grind cut edges of tile abutting trim, finish, or built-in items for straight aligned joints. Fit tile closely to electrical outlets, piping, fixtures, and other penetrations so plates, collars, or covers overlap tile.

END OF SECTION 093000

SECTION 099726
SWIMMING POOL PLASTER

PART 1- GENERAL

1.1 SUMMARY

- A. Provide a conventional white marble plaster interior finish to the pool structure. A ceramic tile trim shall be furnished and installed on the pool perimeter deck tile band, recessed wall steps, depth markings, wall targets, floor lane markings and all other tile installations as shown and detailed on the contract drawings and in strict accordance with these specifications.
- B. Refer to the Swimming Pool Tile Specification Section 093000. Provide water analysis and pre-fill requirements.

1.2 SUBMITTALS

A. Samples

- 1. Prepare 12-inch square panel at the site showing color and texture for pool plaster. Finished plaster work shall match the approved sample panel.

B. Certificates

- 1. Submit certificates attesting that the materials furnished meet the requirements specified herein.

C. Test Report

- 1. Submit results of domestic water analysis and calculation of amounts of chemicals required to balance pool water on initial fill of pool.

1.3 PRODUCT DELIVERY AND STORAGE

- A. Deliver manufactured materials to site in manufacturers' original unbroken packages or containers bearing manufacturers' name and brand labels. Keep cementitious materials dry until ready to be used and stored off the ground, under cover and away from damp surfaces.

1.4 JOB CONDITIONS

- A. Apply plaster in swimming pool only when ambient temperature is above 40 degrees F and below 90 degrees F, and protect applied plaster from rapid drying by sun or wind until curing is completed or pool is filled with water. Confirm and comply with all applicable manufacturers installation requirements.

1.5 QUALITY ASSURANCE

- A. Plaster installers shall have two years experience in similar pool projects which the Owner may require written proof thereof and proper tools to install plaster.

PART 2- PRODUCTS

2.1 GENERAL MATERIALS AND REQUIREMENTS

A. Portland Cement

1. ASTM C150, type I white Portland cement.

B. Hydrated Lime

1. ASTM C206, type S.

C. Aggregates for Conventional Pool Plaster Finish Coat

1. White marble aggregates uniformly graded within following limits, all passing the no. 30 sieve (percentage retained (by weight plus or minus 2%) on each sieve):

<u>Sieve Size</u>	<u>Minimum</u>	<u>Maximum</u>
a. 30	0	0
b. 50	25	50
No. 100 75	90	
No. 200 90	100	

D. Water

1. Clean, fresh, from domestic potable source.

E. Bonding Agent

1. If conventional pool plaster finish is to be used, use Laticrete 8510 bonding admix in accordance with the manufacturer's recommendation as manufactured by LATICRETE International, Inc. or approved equal.

F. Proportions and Mixing

- 1.1_ Materials are specified on a volume basis and shall be measured in approved containers which will ensure that the specified proportions will be controlled and accurately maintained during the progress of the work. Measuring materials with shovels ("shovel count") is not permitted.

- 1.2_ Conventional White Marble Pool Plaster Finish Coat: Mix finish in proportion of one part by volume of white Portland cement to not more than two parts by volume of aggregates (specified white marble dust).

1.3_ Mixing

- a. Perform mixing in approved mechanical mixers of the type in which quantity of water can be controlled accurately and uniformly. While mixer is in continuous operation, charge approximately 90% of estimated quantity of water, half of sand, all cement, and the other one-half of the sand into mixer in that sequence and mix thoroughly with remainder of water until mixture is uniform in color and consistency. Avoid excess mixing to prevent hasty solution of cement resulting in accelerated set. Discard plaster that has begun to set before it is used; re-tempering is not allowed. Do not use any caked or lump materials. Completely empty mixer and mixing boxes after each batch is mixed and keep free of old plaster.

PART 3- EXECUTION

3.1 PREPARATION OF SURFACES AND BOND COAT

- A. Clean base surfaces of projections, dust, loose particles, grease, bond breakers, and foreign matter; make sufficiently rough to provide a strong mechanical bond. Wash entire concrete pool shell with acidic solution within 24 hours of plastering. Do not apply plaster directly to the surfaces of masonry or concrete that is coated with any acidic solution compound or similar agent until compound or agent is completely removed by water blasting. Thoroughly wash entire surface with 2,000 psi high-pressure water immediately prior to plastering. Wet cementitious base surfaces with a fine fog water spray to produce a uniformly moist condition and check screeds, pool equipment, and accessories for correct alignment before plastering is started. Do not apply plaster to base surfaces containing frost. Install temporary coverings as required to protect adjoining surfaces from staining or damage by plastering operations.
- B. Scrub bond coat into the prepared concrete surface immediately prior to plastering. Use stiff bristle brush to ensure total coverage and penetration of the bond coat slurry.

3.2 APPLICATION OF PLASTER

A. General

- 1. Confirm all application requirements with the manufacturer. Apply finish plaster to the properly prepared substrate at the minimum thickness required by the manufacturer, but no less than 3/8 inch thickness at any location. Apply finish plaster by hand or machine. If plastering machine is used, control fluidity of plaster to have a slump not exceeding 2-1/2 inches when tested using a 2" by 4" by 6" high slump cone. Do not add additional water to the mix subsequent to determining water content to meet this slump. Perform slump test according to following procedure:
 - a. Place cone on level, dry non-absorptive base plate.
 - b. While holding cone firmly against base plate, fill cone with plaster taken directly from hose or nozzle of plastering machine, tamping with a metal rod during filling to release all air bubbles.
 - c. Screed off plaster level with top of cone. Remove cone by lifting it straight up with a slow and smooth motion.
 - d. Place cone in a vertical position adjacent to freed plaster sample using care not to jiggle base plate.
 - e. Lay straightedge across top of cone being careful not to vibrate cone; measure slump in inches from bottom edge of straightedge to the top of

B. Workmanship

- 1. Unless otherwise required by the manufacturer, apply finish plaster in two coats by "double-back" method with second coat applied as soon as first coat is tamped and initially floated. Apply plaster with sufficient pressure to provide a good bond on bases. Work plaster to screeds at intervals of from 5 feet to 8 feet on straight

surfaces. Apply smooth trowel finish without waves, cracks, trowel marks, ridges, pits, crazing, dis-coloration, projections, or other imperfections. Form plaster carefully around curves and angles, well up to screeds. Take special care to prevent sagging and consequent drooping of applications. Produce surfaces free of visible junction marks in finish coat where one day's work adjoins another. Finish proprietary plaster as required by the manufacturer.

C. Curing

1. Curing plaster with fine fog water spray applied to finish coat as frequently as required to prevent dry-out of plaster. Keep plaster damp until pool is filled. Prevent damage or staining of plaster by troweling or curing.

D. Patching, Pointing, and Cleaning Up

1. Upon completion, cut out and patch loose, cracked, damaged, or defective plaster; patches matching existing plaster in texture, color, and finish, flush with adjoining plaster. Perform pointing and patching of surfaces and plasterwork abutting or adjoining any other finish work in a neat and workmanlike manner. If 10 percent or more of the pools plaster finish is found to be defective, the plaster shall be removed and replaced complete from all surfaces. Remove plaster droppings or spattering from all surfaces. Leave plaster surfaces in clean, unblemished condition ready for pool filling. Remove protective coverings from adjoining surfaces. Remove rubbish and debris from the site.

3.3 PRE-FILL SPECIFICATION

- A. Owner shall analyze the domestic water with which the pool will be filled within 2 weeks of the plaster date, and shall determine types and quantities of chemicals required to ensure calcium-balanced water immediately upon the completion of water filling.
 1. Owner shall have on hand quantities of the chemicals as determine above, plus 25% overage for follow-up treatment. These chemicals, typically including calcium chloride, bicarbonate of soda, and muriatic acid are in addition to standard bromine/chlorine products and alkalizer/pH control products required elsewhere.
- B. The pool shall not be plastered until directed by the Owner's representative and the filtration system and chlorination system are complete and ready for start-up. The Owner shall supply all chemicals required for treatment of the pool water.

END OF SECTION 099726

SECTION 099860
EXPOSED AGGREGATE POOL

PART 1 GENERAL

1.1 SECTION INCLUDES

- A. Preparation of existing pool surfaces.
- B. Exposed aggregate pool finish.
- C. Pool start-up, including filling, adjusting chemistry, and brushing for specified initial start-up period.

1.2 RELATED SECTIONS

- A. Section 09300 - Tile.

1.3 SUBMITTALS

- A. Submit under provisions of Section 01300.
- B. Selection Samples: Color samples showing manufacturer's full selection.
- C. Manufacturer's installation instructions.
- D. One copy of each of the following, for Owner's use:
 - 1 National Spa and Pool Institute 'Pool Plaster Technology.'
 - 2 National Plasterers Council 'Start-Up Do's and Don'ts for Newly Plastered Swimming Pools.
 - 3 National Plasterers Council 'Care Tips for New Swimming Pool Plaster.'
- E. Submit batch numbers of bags used to Owner for warranty purposes.

1.4 QUALITY ASSURANCE

- A. Installer Qualifications: Experienced in installation of pool plasters or trained by coating manufacturer.

1.5 WARRANTY

- A. Provide manufacturer's warranty to pool owner.

1.6 MAINTENANCE MATERIALS

- A. Provide one bag of each batch used in mix to Owner, with description of mix ratio used and installation instructions, for Owner's use in making repairs.

PART 2 PRODUCTS

2.1 MANUFACTURERS

- A. Requests for substitutions will be considered in accordance with provisions of Section 01600.
- B. Substitutions: Shall be submitted in Bid Response for Owner approval.

2.2 MATERIALS

- A. Pool Coating: SGM Diamond Brite (tm) exposed aggregate finish, made with 100 percent quartz aggregate and polymer modified cement or approved equal.
 - 1. Color: As selected from manufacturer's full line.

2. Color: White
 3. Provide enough material to have sufficient quantity for replacement of unsatisfactory work.
- B. Bond Coat: SGM Bond Kote or approved equal.
- C. Hydraulic Cement (Pool Patch): SGM Instant Hydraulic Cement or approved equal.
- D. Patching Cement: SGM Vinyl Patching Compound or SGM Sand Topping Mix and Concrete Bonding Agent or approved equal.
- E. Water: Potable water without detrimental minerals, metals, hardness, or alkalinity; if in doubt, verify quality with coating manufacturer.

PART 3 EXECUTION

1.3 PREPARATION

- A. Examine pool surfaces to identify conditions that might interfere with proper bonding of coating.
1. Look for algae, mold, or mildew.
 2. Look for dirt, paint, mortar droppings, patching compounds, loose tile, cracked plaster, etc.
 3. Identify hollow spots in plaster by sounding.
- B. Clean pool surfaces of all material that might interfere with proper bonding of coating.
1. Clean with high pressure water or by sand blasting.
 2. Wash with chlorine until algae, mold, and mildew are gone.
 3. Wash oil and grease spots using trisodium phosphate and water; soak if necessary.
- C. Remove and repair all hollow and delaminated plaster.
1. Saw an area 3 inches around bad spots and remove plaster inside the saw cut.
 2. Undercut the edges of remaining plaster.
 3. Fill holes with specified patching cement to level of existing plaster.
- D. Remove loose tile and fittings; remove 2 inches of tile and underlying plaster and undercut 3/8 inch.
- E. Stop water penetration from outside pool. Plug cracks and leaks around fittings using hydraulic cement (pool patch).
- F. Etch cleaned surface with muriatic acid solution. Use concentration necessary to clean and roughen surface; smooth surfaces may require higher concentration. Neutralize surface with solution of baking soda and water.
- G. Plug pool inlets and outlets to prevent clogging.
- H. Mark location of fittings using tape on coping or on a measured drawing.
- I. Provide sump pump at main drain to remove all running and standing water.

3.2 INSTALLATION

- A. Do not begin installation until concrete pool shell has cured at least 28 days.
- B. Apply coating in accordance with coating manufacturer's instructions and recommendations.
- C. On existing plastered surfaces, apply bond coat with stippled finish.
- D. Mix coating to produce best quality and consistent color throughout. If material from more than one batch number is used, mix all batches together for color consistency.
- E. Apply, trowel, and expose aggregate using methods and sequence selected to produce the most uniform finish. Avoid practices that may cause washouts, shadows, streaks, or discoloration.
- F. At areas that will be above water line, take care to avoid blisters or hollows and water cure for 7 to 28 days to reduce possibility of shrinkage cracking.

G. Replace areas of non-uniform appearance.

3.3 START-UP

- A. Allow coating to air dry before filling pool; avoid filling too soon that could cause mottling; avoid drying out causing shrinkage cracking.
- B. Filter pool water using a carbon tank and sequestering agent to remove contaminants that might cause staining.
- C. Fill pool and start circulation system when water level is above return inlets; circulate water continuously for the first 3 days.
- D. Test water and adjust chemistry to best avoid discoloration and scale. Refer to coating manufacturer's recommendations and National Spa and Pool Institute 'Pool Plaster Technology' and National Plasterer's council 'Start-Up Do's and Don't for Newly Plastered Swimming Pools.'
- E. Brush entire coated surface twice a day for the first 3 days. Thereafter, brush entire surface once a day for 2 weeks.
- F. Do not use wheeled vacuums for at least 14 days (to avoid wheel marks) and do not install automatic vacuums for at least 28 days.

END OF SECTION

SECTION 224000
PLUMBING FIXTURES

PART 1 - GENERAL

1.1 SECTION REQUIREMENTS

- A. Submittals: Product Data for each type of plumbing fixture, including trim, fittings, accessories, appliances, appurtenances, equipment, and supports.
- B. Regulatory Requirements: Comply with requirements in Public Law 102-486, "Energy Policy Act," about water flow and consumption rates for plumbing fixtures.

PART 2 PRODUCTS

2.2 SKIMMERS

- A. Auto-Skim Series Skimmers: 1 ½" FIP Pipe Size; Square Cover Style; 5 ¼" Throat Length. ¾ inch auxiliary knockout port (dimensions are approximate; actual dimensions to be determined by Contractor to complement existing plumbing) or approved equal.
- B. Basis-of-Design Product: Hayward Auto Skimmer SP10821 1 1/2" FIP or approved equal. Hayward Industries, Inc., 620 Division Street, Elizabeth, NJ 07201 (dimensions are approximate; actual dimensions to be determined by Contractor to complement existing plumbing.)

2.3 EQUIPMENT

- A. Check Valve: (Contractor shall determine appropriate check valve to complement existing plumbing.)
- B. Basis-of-Design Product: Submit product specifications for approval.

PART 3- EXECUTION

3.1 EQUIPMENT INSTALLATIONS

- A. The CONTRACTOR shall assemble and install all equipment, special parts and accessories as shown on pool drawings, specifications and shop drawings of the equipment suppliers.
- B. CONTRACTOR to install all equipment and systems in accordance with manufacturer's directions. Equipment shall all be assembled and in place for final observation.

END OF SECTION 224000

SECTION 31 2323.33

FLOWABLE FILL

PART 1 GENERAL

1.1 SECTION INCLUDES

- A. Flowable fill (cement stabilized backfill).

1.2 RELATED SECTIONS

- A. 03 3000 – CAST-IN-PLACE CONCRETE

1.3 SUBMITTALS

- A. Submit the following in accordance with project submittal procedures.
 1. Material certifications. A complete list of materials including type; brand; source and amount of cement, fly ash, pozzolans, ground slag, and admixtures; and applicable reference specifications shall be included in the mix design submittal. Provide design mixes and test reports.
 2. Provide design mixes and test reports.
 3. Batch tickets.
 4. Field test reports.

1.4 DESCRIPTION

- A. Flowable fill is a self-leveling slurry of cement, fly ash, aggregates, admixtures, and water with low final strength so can be hand dug later.
- B. Flowable fill may be used for trenches, pipe structures, fill for abandoned water and sewer lines, and other works where cavities exist and firm support is required.
- C. The use of flowable fill around or adjacent to utility lines or structures shall be reviewed and approved by the Engineer. Flowable fill shall not be around or adjacent to utility lines that have requirements for movement.

1.5 QUALITY ASSURANCE

- A. When work or portions of work of this section are completed and require testing, notify the Engineer.
- B. Ensure all required cast-in-place concrete, embedment items, and utility work has been completed prior to placing flowable fill.

1.6 JOB CONDITIONS

- A. Perform concrete washout, trucks and mixers, in a designated and controlled area to prevent the runoff of washout material and the co-mingling of unset concrete with storm water. Properly dispose of all hardened excess concrete.

PART 2 PRODUCTS

2.1 MATERIALS

- A. Cement: ASTM C 150, Type I or Type II.
- B. Fine and Coarse Aggregates: Conform to ASTM C 33. Provide a uniform mixture of fine aggregate or fine and coarse aggregate, as determined by ASTM D 422.

Aggregate Mixture Gradation Requirements

Sieve Size	Percent Passing
1 inch	100
3/8 inch	95 – 100
No. 4	80 – 100
No. 8	60 – 95
No. 16	45 – 80
No. 30	25 – 60
No.50	5 – 45
No. 100	5 – 35
No. 200	0 - 30

- C. Water: Potable water that is clean and not detrimental to concrete.
- D. Fly Ash: Conform to ASTM C 618, Class C or Class F.
- E. Air Entrainment: Conform to ASTM C260. Air entrainment may be between 6 and 25 percent. Air entraining is not required for below grade installation in areas not subject to freeze/thaw cycles.

2.2 Proportioning And Physical Property Requirements

- A. Provide a flowable fill mix design in accordance with the following limits:
 - 1. Cement, maximum 50 lbs/yd³

2. Fly ash, from 150 lbs/yd³ to 300 lbs/yd³
3. Air content, optional
4. Slump, from 6 to 11 inches
5. Water/Cement ratio, proportioned by weight to produce a slump within limits.
6. Consistent aggregate throughout the concrete mixture
7. Compressive strength will not exceed 150 psi at 28 days.

2.2 FLOWABLE FILL

- A. Mix and deliver flowable fill in accordance with ASTM C94.
- B. Use accelerating admixtures in cold weather only when approved by Engineer. Use of admixtures will not relax cold weather placement requirements.
- C. Use set retarding admixtures during hot weather only when approved Engineer.
- D. Do not use calcium chloride as an admixture.
- E. Add air-entraining agent if required to produce a flowable mix.

PART 3 EXECUTION

3.1 EXAMINATION

- A. Verify that all items of cast-in-place concrete, grading, trenching, and all utilities and other embedded items are in place prior to placing flowable fill.
- B. Utilities that are subject to required movement (e.g., steam and condensate lines), shall not be embedded in flowable fill or otherwise have restricted movement.
- C. Flowable fill shall not be used as a substitute for sand bedding or earth backfill for primary utilities unless approved by the Engineer.

3.2 PREPARATION

- A. Remove all loose material from the uneven tuff and the concrete structures.
- B. Set elevation marks or otherwise determine the proper top elevation for the flowable fill.

3.3 PLACEMENT OF FLOWABLE FILL

- A. Notify Engineer a minimum of 48 hours prior to placement of flowable fill.
- B. Flowable fill may be placed by direct discharge from the truck, by pumping, or by other approved methods.
- C. The flowable fill shall be placed in a uniform manner that will prevent voids or segregation of the bedding and filling material. If required, the flowable fill shall be consolidated with internal vibrators.

- D. Pipes, reinforcement, inserts, or other embedded parts shall be placed, supported, and secured in a manner that shall prevent the flowable fill from displacing, sagging, or from floating embedded items.
- E. Flowable fill shall be brought up uniformly to the fill line shown on the plans. Formed walls or other bulkheads shall be constructed to withstand the exerted hydrostatic pressure and confine the material within a dedicated space.
- F. Placement of flowable fill shall start only when weather conditions are favorable. The temperature shall be at least 35 degrees F and rising. Flowable fill shall not be placed on frozen ground or when it is raining.

3.4 CURING AND PROTECTION

- A. Immediately after placement, protect flowable fill from premature drying, excessively hot or cold temperatures and mechanical injury.
- B. The flowable fill shall not be subjected to load and shall remain undisturbed by construction activities for at least 24 hours after placement.

3.5 FIELD QUALITY CONTROL

- A. Testing of flowable fill is not necessarily required.
- B. For field testing use a standard (15 lb) T-post driver to drive a #6 reinforcing bar with a flat end into the flowable fill material 24 hours after placement. Lift the driver until the bottom of the driver is even with a mark located 6 inches below the top of the rebar and then allow it to fall under its own weight. Remove and replace the flowable fill if fewer than 6 blows or more than 25 blows are required to drive the rebar 12 inches into the fill.
- C. Provide unobstructed access to work and cooperate with appointed firm.

3.6 DEFECTIVE FLOWABLE FILL

- A. Do not accept or place defective flowable fill that is not in conformance with acceptance criteria. Return the fresh flowable fill to the supplier.
- B. Defective flowable fill is material having excessive honeycomb, embedded debris, higher than maximum compressive strength, or not conforming to required lines, details, dimensions, tolerances or specified requirements. Repair or replace defective flowable fill as directed by the Engineer.
- C. Replace flowable fill not in conformance with details, tolerances, and other construction requirements at Contractor's expense.

END OF SECTION

Baby Pool Renovation

City of Fairhope Project No. REC004-12



DRAWING SCHEDULE

- A1 - POOL DEMOLITION PLAN
- A2 - POOL DEMOLITION PLAN
- A3 - NOTES AND DETAILS
- A4 - NOTES AND DETAILS
- A5 - POOL REPAIR PLAN
- A6 - POOL REPAIR PLAN
- A7 - POOL REPAIR PLAN
- A8 - FIXTURE DETAILS
- A9 - NOTES AND DETAILS
- A10 - DETAILS



BABY POOL RENOVATION

POOL DEMOLITION PLAN

803 GREENO RD.
FAIRHOPE, AL 36532

JOB NO: 2012.008.00	DRAWN BY: AIKENS	DATE: 7/23/12	FAIRHOPE PROJECT NO: REC004-12
------------------------	---------------------	------------------	-----------------------------------



ARCHITECTS
ENGINEERS

311 FELS AVENUE FAIRHOPE, AL 36532
PH: 251-929-0551 FX: 251-929-0552
www.besfairhope.com

SHEET

T1

THIS DRAWING REPRESENTS GENERAL REQUIREMENTS FOR THE PROJECT AND IS NOT TO BE CONSIDERED A CONTRACT DOCUMENT. THE CONTRACTOR SHALL BE RESPONSIBLE FOR OBTAINING ALL NECESSARY PERMITS AND APPROVALS FROM THE CITY OF FAIRHOPE AND THE STATE OF ALABAMA. THE CITY OF FAIRHOPE IS NOT RESPONSIBLE FOR ANY DAMAGE TO PERSONS OR PROPERTY ARISING FROM THE USE OF THIS DRAWING. THE CITY OF FAIRHOPE IS NOT RESPONSIBLE FOR ANY DAMAGE TO PERSONS OR PROPERTY ARISING FROM THE USE OF THIS DRAWING.

SEQUENCE OF DEMOLITION OPERATIONS

1. EMPTY POOL
2. UTILIZE EXISTING GATE FOR ACCESS TO SITE
3. MARK SAW CUT LINES (2' FROM EDGE OF POOL)
4. SET UP BARRIER TO PREVENT ENTRANCE BY UNWANTED PATRONS
5. CUT OUT MARKED CONCRETE
6. BREAK APART CUT CONCRETE
7. REMOVE CUT CONCRETE DECK
8. REMOVE EXISTING POOL PLASTER
9. REMOVE POOL FIXTURES
10. REMOVE EXISTING FILL FROM PERIMETER OF POOL (TO BOTTOM OF POOL: 4' MAXIMUM DEPTH)
11. UPON REMOVAL OF PLASTER, THE CONTRACTOR'S ENGINEER MUST INSPECT THE PLUMBING OF THE POOL. DAMAGED PLUMBING COULD BE THE RESULT OF POOL SETTLEMENT.
12. IF PLUMBING DAMAGE IS DISCOVERED, PLUMBING WILL HAVE TO BE REPAIRED
13. CLEAN AREA OF ALL CLUTTER THROUGHOUT ENTIRE CONSTRUCTION PROCESS

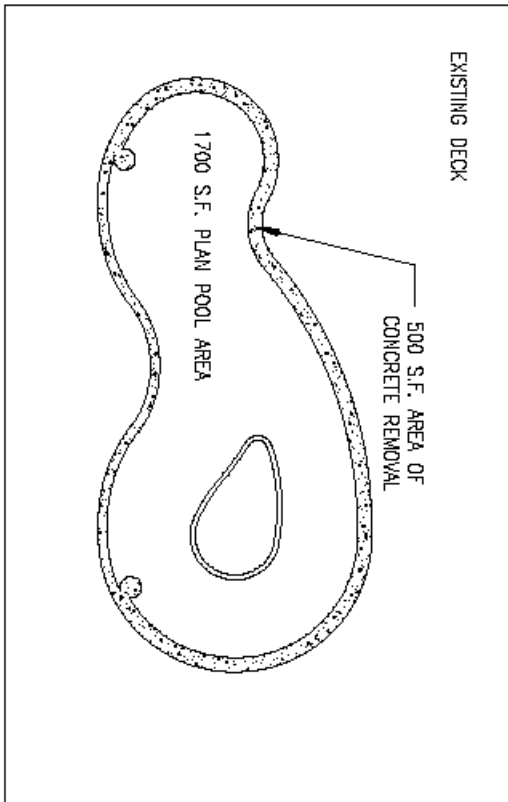

SW EDGE OF POOL AREA OF CONCRETE REMOVAL



PROJECT AREA



NORTH END OF POOL AREA OF CONCRETE REMOVAL



EAST END OF POOL AREA OF CONCRETE REMOVAL

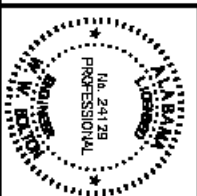

BABY POOL RENOVATION

POOL DEMOLITION PLAN

803 GREENO RD.
FAIRHOPE, AL 36532

JOB NO: 2012.008.00	DRAWN BY: AIKENS	DATE: 7/23/12	FAIRHOPE PROJECT NO: REC004-12
------------------------	---------------------	------------------	-----------------------------------



ARCHITECTS
ENGINEERS

311 FELS AVENUE FAIRHOPE, AL 36532
PH: 251-929-0551 FX: 251-929-0552
www.besfairhope.com

A1

SHEET

THIS DRAWING REPRESENTS SERVICES PERFORMED BY A L.S.D. AND FOR SPECIFIC USE OF THIS PROJECT AND IS NOT TO BE COPIED, REPRODUCED, OR ALTERED WITHOUT THE EXPRESS WRITTEN CONSENT OF THE FLSA, INC. PERMISSION IS AUTHORIZED TO APPROVE THIS USE. UNAUTHORIZED USE IS SUBJECT TO LEGAL ACTION UNDER STATE AND FEDERAL LAW.

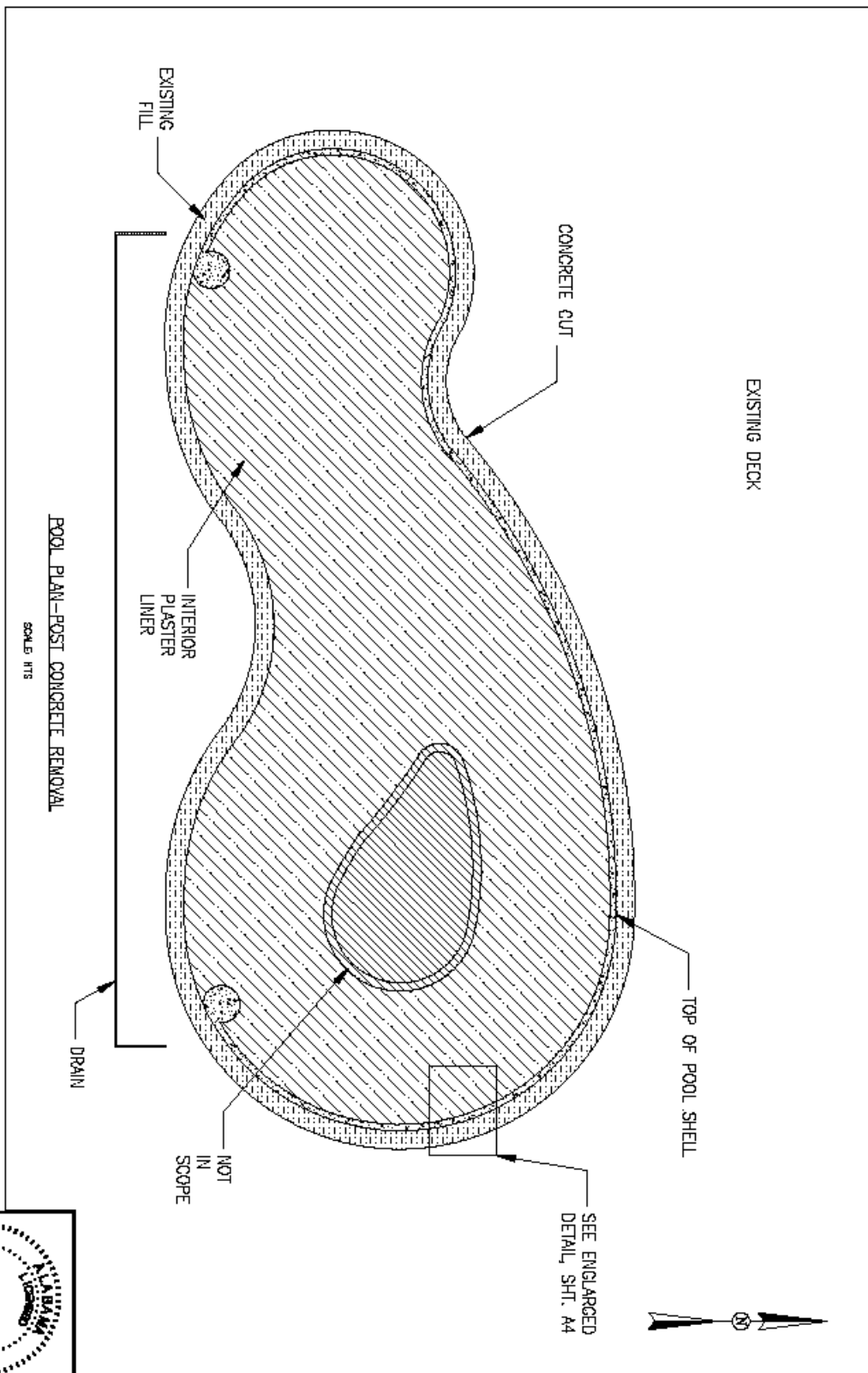

HATCH SCHEDULE



EXISTING FILL



PLASTER LINER



TOP OF POOL SHELL



NOT IN SCOPE

POOL PLAN-POST CONCRETE REMOVAL

SCALE: HTS

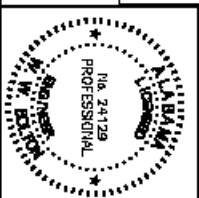

BABY POOL RENOVATION

POOL DEMOLITION PLAN
803 GREENO RD.
FAIRHOPE, AL 36532



ARCHITECTS
ENGINEERS

311 FELS AVENUE FAIRHOPE, AL 36532
PH: 251-929-0551 FX: 251-929-0552
www.besfairhope.com

SHEET

A2

JOB NO: 2012.008.00	DRAWN BY: AKENS	DATE: 7/23/12	FAIRHOPE PROJECT NO: REC004-12
------------------------	--------------------	------------------	-----------------------------------

GENERAL DEMOLITION NOTES

- I. ENTRANCE TO SITE
 - A. UTILIZE EXISTING GATE TO ENTER SITE. DO NOT REMOVE ANY SECTIONS OF FENCE.
- II. LAYING YARD
 - A. POSITION LAYING YARD IN THE BOX DEPICTED ON SHEET A4. UTILIZE PLASTIC GROUND COVER FOR LAYING YARD. STORE ALL MATERIALS, TOOLS, ETC.
- III. CONCRETE SAW
 - A. UTILIZE A CONCRETE SAW THAT IS CAPABLE OF CURVED CUTS. A CURVED CUT IS REQUIRED TO OBTAIN THE DESIRED CONTROL JOINT.
- IV. SITE DAMAGE PREVENTION
 - A. KEEP ALL HEAVY MACHINERY OFF OF EXISTING SLAB TO PREVENT SLAB CRACKING.
- V. REMOVAL OF FILL
 - A. REMOVE EXISTING FILL TO BOTTOM OF POOL. (MAXIMUM DEPTH OF POOL IS 4'.)
 - B. HAUL FILL OFF SITE. DO NOT LEAVE FILL ON SITE OR AROUND SITE.
- VI. CONTRACTOR RESPONSIBILITY
 - A. CONTRACTOR IS RESPONSIBLE FOR MEANS AND METHODS OF CONSTRUCTION. THE SEQUENCE OF OPERATIONS FOR DEMOLITION IS FOR CLARITY ONLY. CONTRACTOR SHALL PROVIDE ACTUAL SEQUENCE OF OPERATIONS FOR APPROVAL.
- VII. ENGINEERING ANALYSIS
 - A. ENGINEERING ANALYSIS IS BASED ON OBSERVATIONS ALONE. NO DESTRUCTION ANALYSIS WAS CONDUCTED.
- VIII. APPROXIMATE AREAS
 - A. ALL EXPRESSED AREAS ARE APPROXIMATIONS ONLY. CONTRACTOR IS RESPONSIBLE FOR OBTAINING ACTUAL MEASUREMENTS.

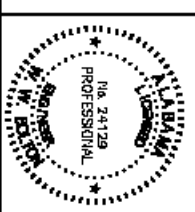

BABY POOL RENOVATION

NOTES AND DETAILS
 803 GREENO RD.
 FAIRHOPE, AL 36532

JOB NO: 2012.008.00	DRAWN BY: A/KENS	DATE: 7/23/12	FAIRHOPE PROJECT NO: REC004-12
------------------------	---------------------	------------------	-----------------------------------



311 FELS AVENUE FAIRHOPE, AL 36532
 PH: 251-929-0551 FX: 251-929-0552
 www.besfairhope.com

SHEET
A3

THIS DRAWING REPRESENTS SERVICE PROVIDED BY B.E.S., INC. FOR SPECIFIC USE OF THIS PROJECT AND IS NOT TO BE COPIED, REPRODUCED, OR ALTERED WITHOUT THE EXPRESS WRITTEN CONSENT OF THE B.E.S., INC. REPRESENTATIVE AUTHORIZED TO APPROVE THIS USE. UNAUTHORIZED USE IS SUBJECT TO LEGAL ACTION UNDER STATE AND FEDERAL LAW.

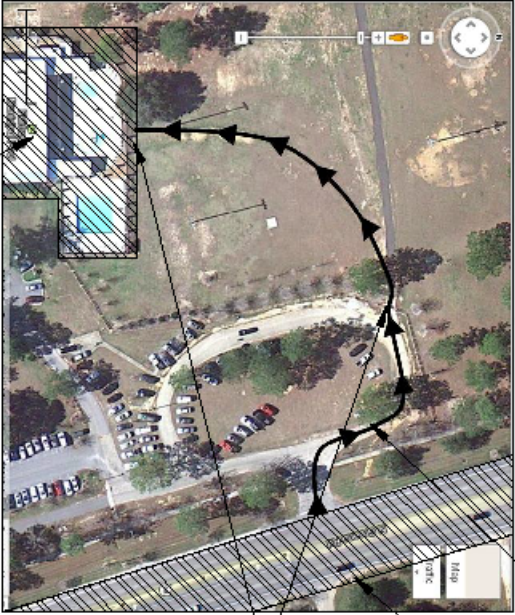

HAUL ROAD

HAUL ROAD

GREENO ROAD

OBTAIN ACCESS TO GATE FROM OWNER

FAIRHOPE POOL COMPLEX

NOTE: NO VEHICLES/HEAVY MACHINERY IS ALLOWED ON POOL DECK.



ENTRY GATE

LAYING YARD

PROJECT AREA W/ LAYING YARD

POOL TO BE REPAIRED

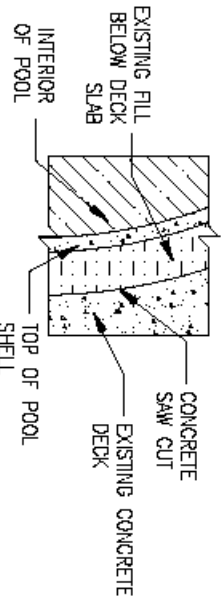

DEMOLITION PLAN DETAIL POST CONCRETE REMOVAL

SCALE: 1/8" = 1'-0"



A4

SHEET

BABY POOL RENOVATION

NOTES AND DETAILS
803 GREENO RD.
FAIRHOPE, AL 36532

JOB NO: 2012.008.00	DRAWN BY: AKENS	DATE: 7/23/12	FAIRHOPE PROJECT NO: REC004-12
------------------------	--------------------	------------------	-----------------------------------



311 FELS AVENUE FAIRHOPE, AL 36532
PH: 251-929-0551 FX: 251-929-0552
www.besfairhope.com

THIS DRAWING REPRESENTS SERVICES PROVIDED BY B.E.S., INC. FOR SPECIFIC USE OF THIS PROJECT AND IS NOT TO BE COPIED, REPRODUCED, OR ALTERED WITHOUT THE EXPRESS WRITTEN CONSENT OF THE B.E.S., INC. REPRESENTATIVE AUTHORIZED TO APPROVE THIS USE. UNAUTHORIZED USE IS SUBJECT TO LEGAL ACTION UNDER STATE AND FEDERAL LAW.

SEQUENCE OF REPAIR OPERATIONS

1. IF PLUMBING DAMAGE IS DISCOVERED, REPAIR THE PLUMBING.
2. MIX AND POUR FLOWABLE FILL.
3. ALLOW FLOWABLE FILL TO CURE.
4. INSTALL FIXTURES BACK INTO POOL.
5. REPAIR SKIMMERS.
6. INSTALL NEW PLASTER POOL SIDING.
7. INSTALL NEW SURFACE LEVEL TILE AND INFORMATIONAL TILE.
8. POUR NEW POOL DECK COPING.
9. USE CONCRETE GROOVER TO MAKE CONTROL JOINTS IN NEW COPING EVERY 20' TO MATCH EXISTING CONTROL JOINTS.
10. UTILIZE BOND BREAKER TO CREATE CURVED CONTROL JOINT AT EDGE OF POOL COPING.
11. ALLOW CONCRETE TO CURE.
12. INSTALL NEW CHECK VALVE IN POOL DRAIN.
13. APPLY DECK COATING OVER NEW CONCRETE AFTER PROPERLY CURED.
14. APPLY SEALANT AND BACKING TO NEW POOL BOUNDARY CONTROL JOINT.
15. REMOVE PERIMETER BARRIERS FROM CONSTRUCTION SITE.
16. ENSURE SITE IS ALWAYS CLEAN.

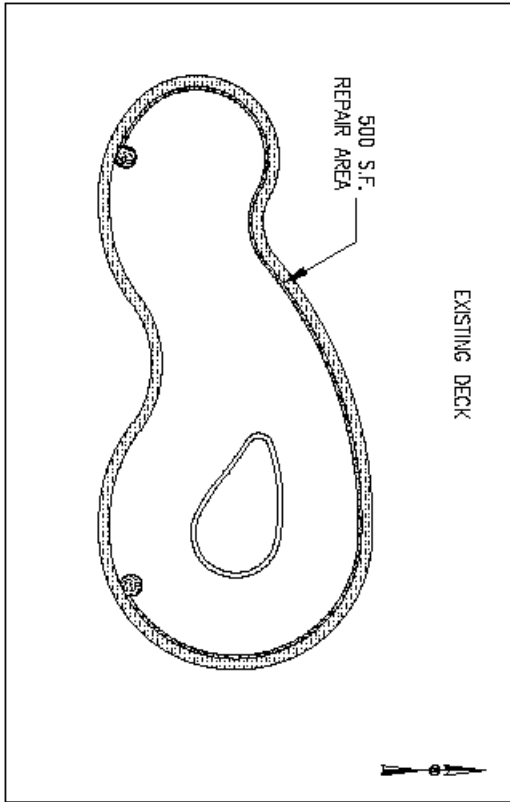

WEST END OF POOL AREA OF CONCRETE REPAIR



PROJECT AREA



NORTH END OF POOL AREA OF CONCRETE REPAIR



EAST END OF POOL AREA OF CONCRETE REPAIR

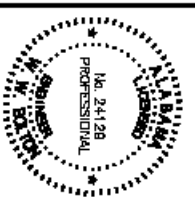

BABY POOL RENOVATION			
POOL REPAIR PLAN			
803 GREENO RD. FAIRHOPE, AL 36532			
JOB NO: 2012.00B.00	DRAWN BY: AIKENS	DATE: 7/23/12	FAIRHOPE PROJECT NO: REG004-12

BES INCORPORATED	ARCHITECTS ENGINEERS
311 FELS AVENUE FAIRHOPE, AL 36532	
PH: 251-929-0551 FX: 251-929-0552	
www.besfairhope.com	

SHEET

A5

THIS DRAWING REPRESENTS CONCEPTS PROVIDED BY BES, INC. FOR YOUR USE ON THIS PROJECT AND IS NOT TO BE COPIED, REPRODUCED, OR ALTERED WITHOUT THE EXPRESS WRITTEN CONSENT OF THE B.E.S., INC. REPRESENTATIVE AUTHORIZED TO APPROVE THIS USE. UNAUTHORIZED USE IS SUBJECT TO LEGAL ACTION UNDER STATE AND FEDERAL LAW.

THIS DRAWING REPRESENTS SERVICE PROVIDED BY B.E.S., INC. FOR SPECIFIC USE OF THIS PROJECT AND IS NOT TO BE COPIED, REPRODUCED, OR ALTERED WITHOUT THE EXPRESS WRITTEN CONSENT OF THE B.E.S., INC. REPRESENTATIVE AUTHORIZED TO APPROVE THIS USE. UNAUTHORIZED USE IS SUBJECT TO LEGAL ACTION UNDER STATE AND FEDERAL LAW.

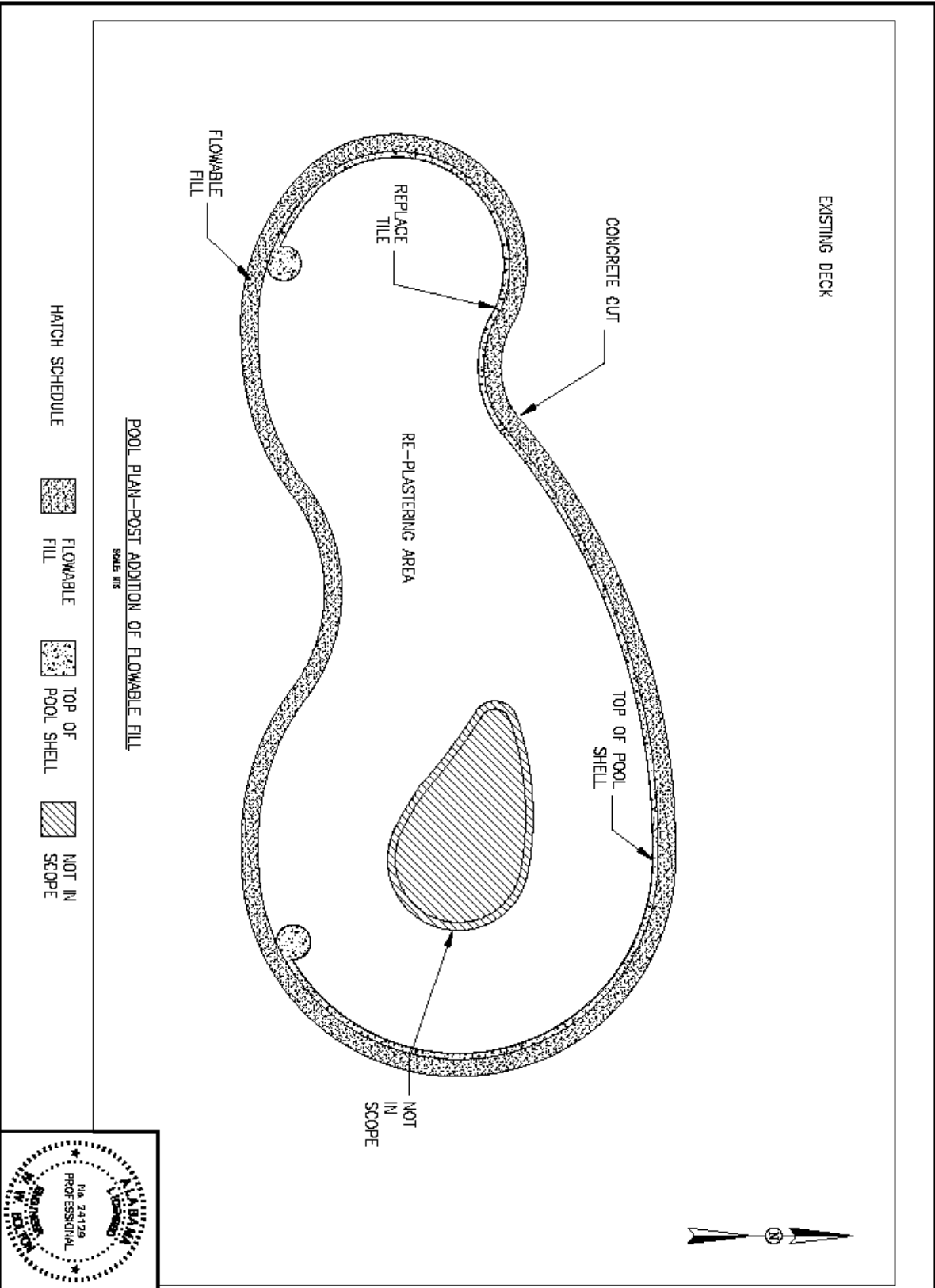

HATCH SCHEDULE



FLOWABLE FILL



TOP OF POOL SHELL



NOT IN SCOPE

POOL PLAN—POST ADDITION OF FLOWABLE FILL

SCALE: 1/8" = 1'-0"



A6
SHEET

BABY POOL RENOVATION

POOL REPAIR PLAN
803 GREENO RD.
FAIRHOPE, AL 36532

JOB NO: 2012.008.00	DRAWN BY: AKENS	DATE: 7/23/12	FAIRHOPE PROJECT NO: REC004-12
------------------------	--------------------	------------------	-----------------------------------

BES ARCHITECTS
INCORPORATED ENGINEERS

311 FELS AVENUE FAIRHOPE, AL 36532
PH: 251-929-0551 FX: 251-929-0552
www.besfairhope.com

THIS DRAWING REPRESENTS ORDERS PREPARED BY B.E.S., INC. FOR SPECIFIC USE ON THIS PROJECT AND IS NOT TO BE COPIED, REPRODUCED, OR ALTERED WITHOUT THE EXPRESS WRITTEN CONSENT OF THE B.E.S., INC. REPRESENTATIVE AUTHORIZED TO APPROVE THIS USE. UNAUTHORIZED USE IS SUBJECT TO LEGAL ACTION UNDER STATE AND FEDERAL LAW.

HATCH SCHEDULE



DECK COATING



NEW COPING



PLASTER LINER



NOT IN SCOPE

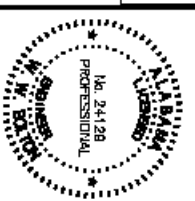

A7

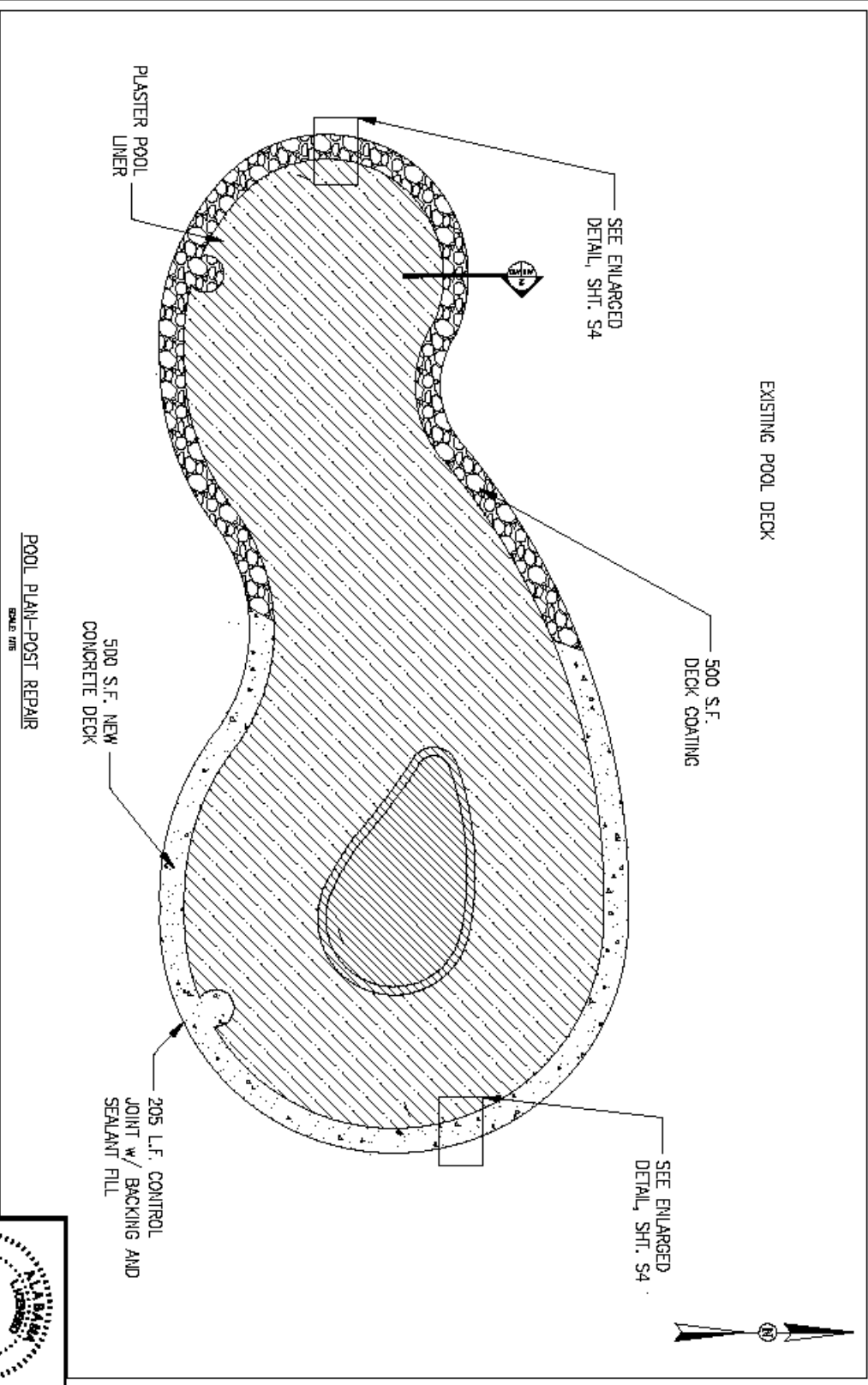

BABY POOL RENOVATION

POOL REPAIR PLAN
 803 GREENO RD.
 FAIRHOPE, AL 36532

JOB NO: 2012.008.00	DRAWN BY: AIKENS	DATE: 7/23/12	FAIRHOPE PROJECT NO: REG004-12
------------------------	---------------------	------------------	-----------------------------------



311 FELS AVENUE FAIRHOPE, AL 36532
 PH: 251-929-0551 FX: 251-929-0552
 www.besfairhope.com

NOTE: MARK LOCATIONS OF EXISTING TILE INFORMATION MARKERS, DEPTH AND APPROXIMATE LOCATION IS INDICATED BELOW.

NOTE: THE BELOW LOCATION OF DRAINS, SKIMMERS, AND JETS ARE APPROXIMATE PRIOR TO DEMOLITION. DRAINS, SKIMMERS, AND JETS SHALL REMAIN IN THE SAME POSITION POST REPAIR.

NOTE: REFER TO SHEET A9 FOR POOL SIDE TILE DETAIL.

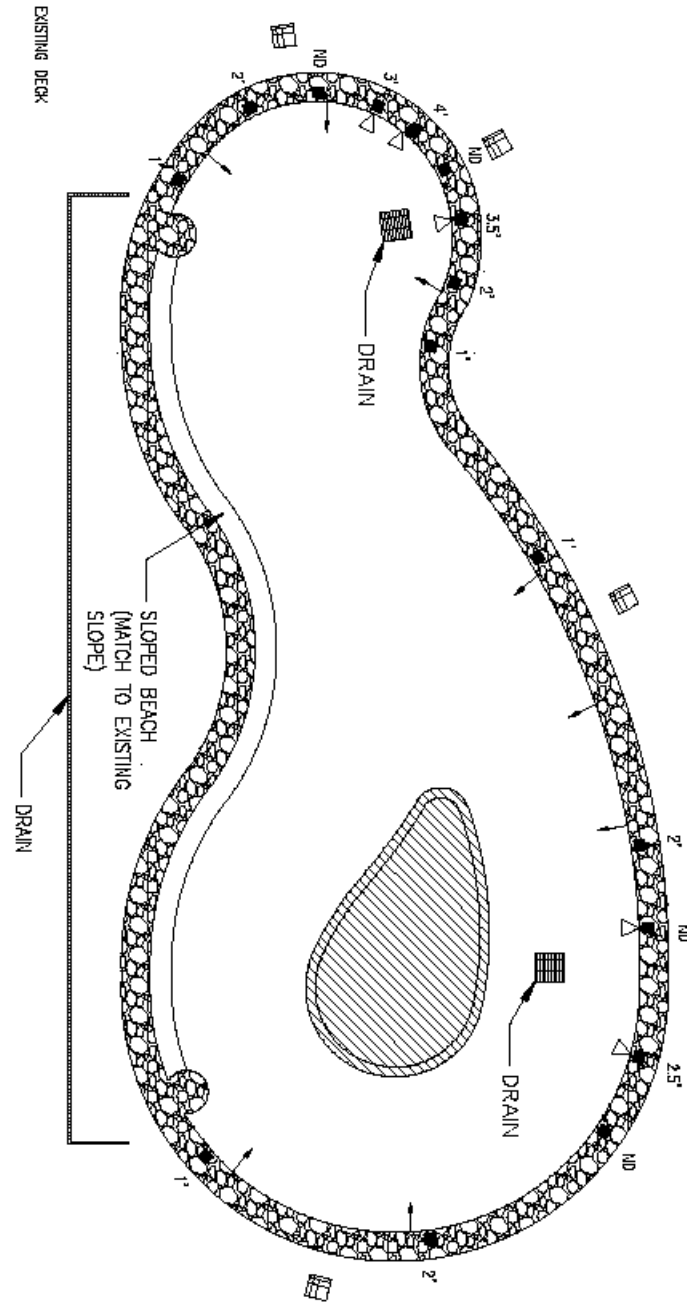

SYMBOL AND HATCH SCHEDULE



DECK COATING



INFORMATION



JET



NO DIVING



SKIMMER



LIGHT

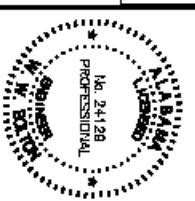

THIS DRAWING REPRESENTS GENERAL PROPOSED BY B.E.S., INC. FOR YOUR USE ON THIS PROJECT AND IS NOT TO BE COPIED, REPRODUCED, OR ALTERED WITHOUT THE EXPRESS WRITTEN CONSENT OF THE B.E.S., INC. REPRESENTATIVE AUTHORIZED TO APPROVE THIS USE. UNAUTHORIZED USE IS SUBJECT TO LEGAL ACTION UNDER STATE AND FEDERAL LAW.

BABY POOL RENOVATION

FIXTURE DETAILS
803 GREENO RD.
FAIRHOPE, AL 36532

JOB NO: 2012.008.00	DRAWN BY: AIKENS	DATE: 7/23/12	FAIRHOPE PROJECT NO: REG004-12
------------------------	---------------------	------------------	-----------------------------------

BES ARCHITECTS
INCORPORATED ENGINEERS

311 FELS AVENUE FAIRHOPE, AL 36532
PH: 251-929-0551 FX: 251-929-0552
www.besfairhope.com

A8

SHEET

GENERAL REPAIR NOTES

- I. DECK COATING
 - A. UTILIZE APPROPRIATE DECK COATING APPLICATOR TO ENSURE A TEXTURED SURFACE.
- II. FLOWABLE FILL
 - A. FLOWABLE FILL SHALL REPLACE EXISTING FILL TO BOTTOM OF EXISTING SLAB. NEW CONCRETE SHALL BE POURED OVER FLOWABLE FILL.
- III. CONCRETE
 - A. ALL CONCRETE SHALL DEVELOP 3,500 PSI MINIMUM COMPRESSIVE STRENGTH IN 28 DAYS.
 - B. UTILIZE A BOND BREAKER TO CREATE CURVED CONTROL JOINT.
 - C. PLACE CONTROL JOINTS IN NEW COPING EVERY 20' TO MATCH EXISTING JOINTS.
 - D. PLEASE SUBMIT METHOD OF BEAM FORM FOR APPROVAL PRIOR TO POUR.
- IV. PLASTER
 - A. TAKE EXTREME CAUTION WHEN REPAIRING POOL PLASTER.
- V. TILE
 - A. REPLACE THE WATER LEVEL TILE.
 - B. REPLACE INFORMATIONAL TILES (I.E. DEPTH TILES/"NO DIVING" TILE)
- VI. SKIMMERS
 - A. REPLACE ALL SKIMMERS.
- VII. CONTRACTOR RESPONSIBILITY
 - A. CONTRACTOR IS RESPONSIBLE FOR MEANS AND METHODS OF CONSTRUCTION. THE SEQUENCE OF OPERATIONS FOR REPAIR IS FOR CLARITY ONLY. CONTRACTOR SHALL PROVIDE SEQUENCE OF OPERATIONS FOR APPROVAL.

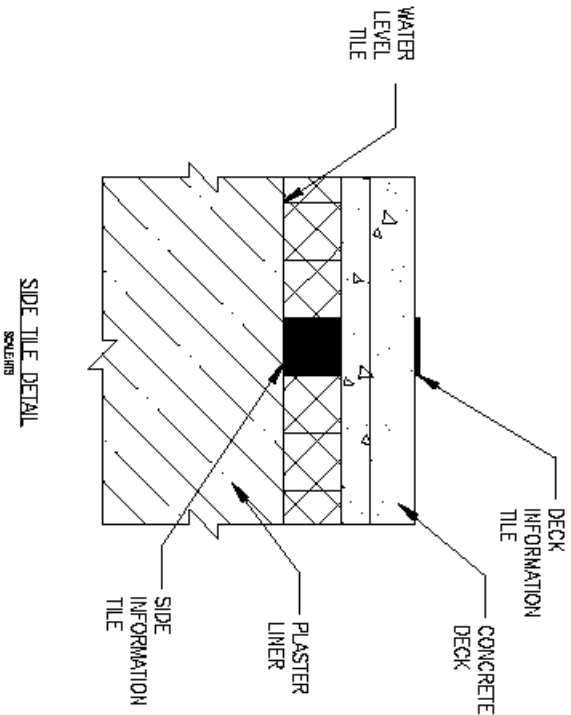

NOTE: APPROXIMATE AREA OF 500 S.F. OF CONCRETE TOPPING IS REQUIRED TO COVER NEW CONCRETE. AN ADDITIONAL 6100 S.F. OF CONCRETE TOPPING IS NEEDED TO COVER THE ENTIRE AREA OF THE POOL DECK.

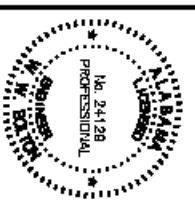

BABY POOL RENOVATION		BES ARCHITECTS ENGINEERS INCORPORATED
NOTES AND DETAILS 803 GREENO RD. FAIRHOPE, AL 36532		
JOB NO: 2012.008.00	DRAWN BY: AIKENS	311 FELS AVENUE FAIRHOPE, AL 36532 PH: 251-929-0551 FX: 251-929-0552 www.besfairhope.com
		DATE: 7/23/12
		FAIRHOPE PROJECT NO: REC004-12

THIS DRAWING REPRESENTS CONCEPT PROPOSED BY B.E.S., INC. FOR SPECIFIC USE ON THIS PROJECT AND IS NOT TO BE COPIED, REPRODUCED, OR ALTERED WITHOUT THE EXPRESS WRITTEN CONSENT OF THE B.E.S., INC. REPRESENTATIVE. AUTHORIZED TO APPROVE THIS USE. UNAUTHORIZED USE IS SUBJECT TO LEGAL ACTION UNDER STATE AND FEDERAL LAW.

SHEET
A9

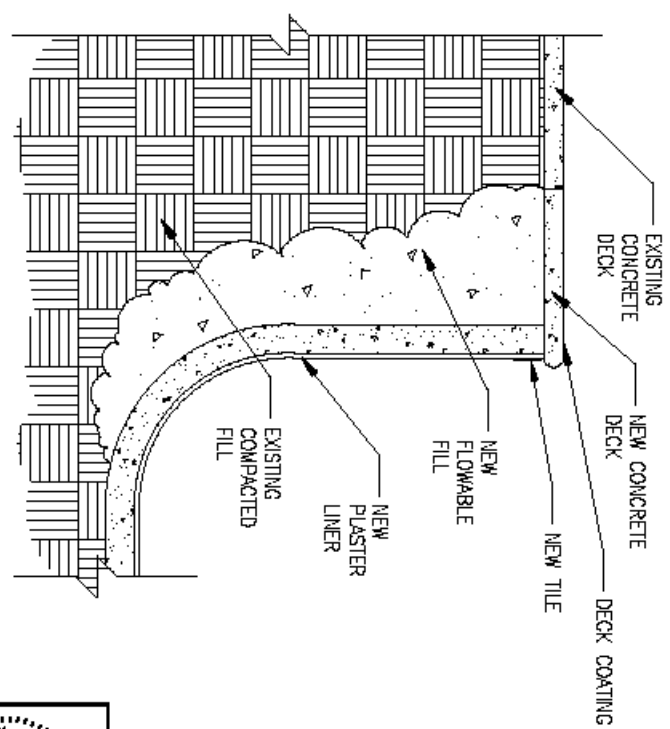
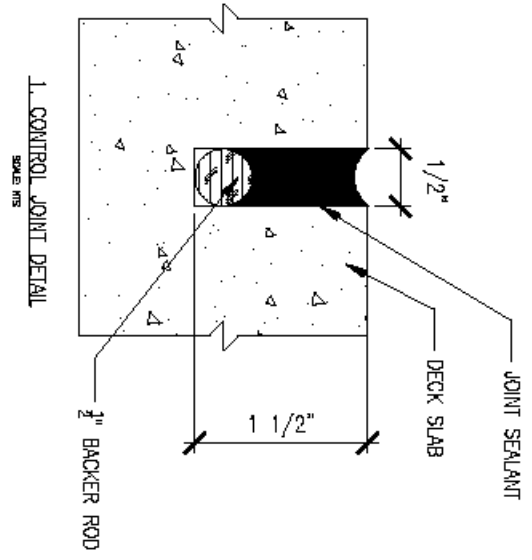
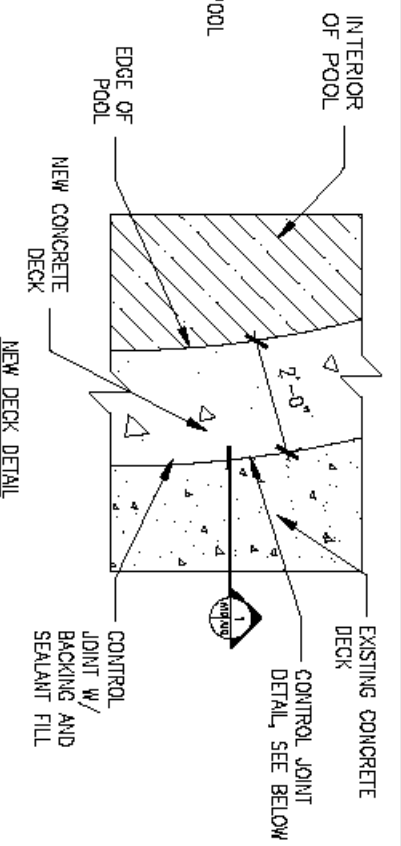
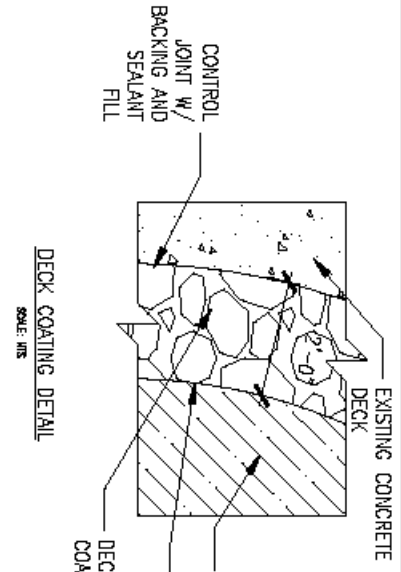

THIS DRAWING REPRESENTS GENERAL PROPOSED BY BES, INC. FOR SPECIFIC USE ON THIS PROJECT AND IS NOT TO BE COPIED, REPRODUCED, OR ALTERED WITHOUT THE EXPRESS WRITTEN CONSENT OF THE BES, INC. REPRESENTATIVE AUTHORIZED TO APPROVE THIS USE. UNAUTHORIZED USE IS SUBJECT TO LEGAL ACTION UNDER STATE AND FEDERAL LAW.

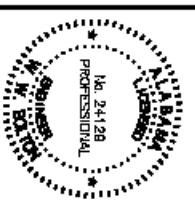

BABY POOL RENOVATION			
DETAILS			
803 GREENO RD. FAIRHOPE, AL 36532			
JOB NO: 2012.008.00	DRAWN BY: AIKENS	DATE: 7/23/12	FAIRHOPE PROJECT NO: REC004-12

BES ARCHITECTS
INCORPORATED ENGINEERS

311 FELS AVENUE FAIRHOPE, AL 36532
PH: 251-929-0551 FX: 251-929-0552
www.besfairhope.com

SHEET
A10

ID	Task Mode	Task Name	Duration	Start	Finish	Predecessors	Sep 9, '12							Sep 16, '12							Sep 23, '12							Sep 30, '12							Oct 7, '12						
							S	S	M	T	W	T	F	S	S	M	T	W	T	F	S	S	M	T	W	T	F	S	S	M	T	W	T	F	S	S	M	T	W	T	F
1		Demolition and Site Work	8 days	Mon 9/10/12	Wed 9/19/12																																				
2		Drain Pool	1 day	Mon 9/10/12	Mon 9/10/12																																				
3		Set-Up of Site	0.5 days	Tue 9/11/12	Tue 9/11/12	2																																			
4		Mark Concrete Cutout	0.5 days	Tue 9/11/12	Tue 9/11/12	3																																			
5		Cut and Remove Concrete	3 days	Tue 9/11/12	Fri 9/14/12	3																																			
6		Remove Plaster and Fixtures	5 days	Tue 9/11/12	Tue 9/18/12	3																																			
7		Remove Existing Fill	2 days	Fri 9/14/12	Tue 9/18/12	5																																			
8		Plumbing Inspection	1 day	Tue 9/18/12	Wed 9/19/12	7																																			
9		Pool Repair	16 days	Tue 9/18/12	Wed 10/10/12																																				
10		Pour Flowable Fill	1 day	Wed 9/19/12	Thu 9/20/12	8																																			
11		Flowable fill Curing	2 days	Thu 9/20/12	Mon 9/24/12	10																																			
12		Install New Plaster	8 days	Tue 9/18/12	Fri 9/28/12	6																																			
13		Pour Concrete Deck	1 day	Mon 9/24/12	Tue 9/25/12	11																																			
14		Concrete Curing	7 days	Tue 9/25/12	Thu 10/4/12	13																																			
15		Install Deck Coating	1 day	Thu 10/4/12	Fri 10/5/12	14																																			
16		Reinstall All Fixtures	1 day	Thu 10/4/12	Fri 10/5/12	12,14																																			
17		Refill Pool	2 days	Fri 10/5/12	Tue 10/9/12	16,15																																			
18		Clean Up Site	1 day	Tue 10/9/12	Wed 10/10/12	17																																			
19		Punch List	1 day	Tue 10/9/12	Wed 10/10/12	17																																			

Project: PoolConstructionSchedule Date: Thu 7/5/12	Task		Project Summary		Inactive Milestone		Manual Summary Rollup		Deadline	
	Split		External Tasks		Inactive Summary		Manual Summary		Progress	
	Milestone		External Milestone		Manual Task		Start-only			
	Summary		Inactive Task		Duration-only		Finish-only			

Item VII
**CITY OF FAIRHOPE, ALABAMA
STANDARD TERMS AND CONDITIONS**

ACCEPTANCE OF AGREEMENT

This Agreement contains all terms and conditions agreed upon by the Owner and Winning bidder. No other agreement, oral or otherwise, regarding the subject matter of this Agreement shall be deemed to exist or to bind either party hereto. The Winning Bidder shall not employ Subcontractors without the express written permission of the Owner. No waiver, alteration, consent or modification of any of the provisions of the Agreement shall be binding unless in writing and signed by the Owner and Contractor. This Agreement shall not be construed against the party or parties preparing it. It shall be construed as if all the parties and each of them jointly prepared this Agreement, and any uncertainty or ambiguity shall not be interpreted against one or more parties.

ACCEPTANCE OF WORK

The City of Fairhope will be deemed to have accepted the Work after the City of Fairhope agrees the Work is completed by signature on delivery or service tickets. In the event Work furnished under the Contract / Agreement / Purchase Order is found to be defective or does not conform to the intent of the Contract / Agreement / Purchase Order, the awarded vendor shall, after receipt of notice from the City of Fairhope, correct the deficiencies. Failure on the part of the awarded vendor to properly correct the deficiencies within the time period allowed will constitute the City of Fairhope's right to cancel the Contract / Agreement / Purchase Order immediately, upon written notice to the awarded vendor.

ADDENDA

All Addenda are part of the Contract Documents. Include resultant costs in the Bid. Addenda will be issued by FAX or Email to all Bidders on record, and posted to the City of Fairhope website www.cofairhope.com. It is the responsibility of the bidder to verify that all addenda have been received, and to include all signed addenda in the bid submission

ADDITIONAL ORDERS

Unless it is specifically stated to the contrary in the bid response, the City of Fairhope reserves the option to place additional orders against a contract awarded as a result of this solicitation at the same terms and conditions; to extend the renewal date until a new bid is in place, if it is mutually agreeable.

APPLICABLE LAW

This Agreement is deemed to be under and shall be governed by and construed according to the laws of the

State of Alabama. Any litigation arising out of the Agreement shall be heard in the Courts of Baldwin County, Alabama.

ASSIGNMENT

The awarded vendor shall not assign the Contract / Agreement /Purchase Order or sublet it as a whole without the express written permission of the City of Fairhope. The awarded vendor shall not assign any payment due them hereunder, without the express written permission of City of Fairhope. The City of Fairhope may assign the Contract / Agreement / Purchase Order, or sublet it as a whole, without the consent of the awarded vendor.

ASSURANCE OF NON-CONVICTION OF BRIBERY

The bidder hereby declares and affirms that, to its best knowledge, none of its officers, directors, or partners and none of its employees directly involved in obtaining contracts has been convicted of bribery, attempted bribery or conspiracy to bribe under the laws of any state or Federal government.

AWARD CONSIDERATION

The following factors will be considered in determining the lowest **responsible** bidder: Overall quality, Conformity with specifications both general and specific, Purposes for which materials or services are required, Delivery dates and time required for delivery, Unit acquisition cost, financial ability to meet the contract, previous performance, facilities and equipment, availability of repair parts, experience, delivery promise, terms of payments, compatibility as required, other costs, and other objective and accountable factors which are reasonable.

AWARD OR REJECTION OF BIDS

The Bid will be awarded to the lowest responsible bidder complying with conditions of the invitation for bids, provided his bid is reasonable and it is in the interest of the City of Fairhope to accept it. The bidder to whom the award is made will be notified at the earliest possible date. The City of Fairhope, however, reserves the right to reject any and all bids and to waive any informality in bids received whenever such rejection or waiver is in the interest to the City of Fairhope.

BACK ORDERS

If it is necessary to back order any items, the vendor must notify the Purchasing Department and advise as to the expected shipping or delivery date. If this date is not acceptable, the City of Fairhope may seek remedies for default.

BID AND PERFORMANCE SECURITY

If bid security is required, a bid bond or cashier's check in the amount indicated on the bid cover must accompany the bid and be made payable to The City of Fairhope of

Baldwin County, Al. Corporate or certified checks are not acceptable. Bonds must be in a form satisfactory to the City and underwritten by a company licensed to issue bonds in the State of Alabama. If bid security fails to accompany the bid, it shall be deemed unresponsive, unless the Purchasing Manager deems the failure to be non-substantial. All checks will be returned to the bidders after the contract has been approved. If a performance bond is required, the successful bidder will be notified after the awarding of the contract.

BRAND NAMES

Reference to brand names and numbers is descriptive, but not restrictive, unless otherwise specified. Bids on equivalent items meeting the standards of quality thereby indicated will be considered, providing the bid clearly describes the article offered and indicates how it differs from the referenced brands. Descriptive literature or manufacturers specifications plus any supplemental information necessary for comparison purposes should be submitted with the bid or the bid on that item may be rejected. Reference to literature submitted with a previous bid or on file with the Division of Purchasing will not satisfy this requirement. The burden is on the bidder to demonstrate that the item bid is equivalent to the item specified in the ITB. Bids without sufficient documentation to fully support equality, may be considered non-responsive. Reference by the City of Fairhope in the ITB to available existing specifications shall be sufficient to make the terms of such specifications binding on the bidder. Unless the bidder specifies otherwise in its bid, it is understood the bidder is offering a referenced brand item as specified in the ITB or is bidding as specified when no brand is referenced. Failure to examine drawings, specifications and instructions will be at the bidder's risk.

BUSINESS LICENSE

The vendor selected to enter into a Contract / Agreement with the City of Fairhope must be licensed to do business in the City of Fairhope prior to commencement of any work under the contract. Delivery of goods or services to the City of Fairhope by Purchase Order have detailed and varied Business License requirements. In all instances that require a business license. Awarded vendor will provide proof of possessing a current City of Fairhope Business License. Prospective bidders will not be required to possess a City of Fairhope Business License prior to award.

CANCELLATION OF / CONTRACT / AGREEMENT / PURCHASE ORDER / LEASE

A purchase order can be canceled in whole or in part when awarded vendor fails to deliver or perform as specified. Cancellation of a purchase order can only be made by a written purchase order change (POC) from the City of Fairhope. A term contract, lease or agreement can be canceled by the City of Fairhope, for justifiable cause, or convenience, by written notice.

CERTIFICATION PURSUANT TO ACT NO. 2006-557

Alabama law (section 41-4-116, code of Alabama 1975) provides that every bid submitted and contract executed shall contain a certification that the vendor, contractor, and all of its affiliates that make sales for delivery into Alabama or leases for use in Alabama are registered, collecting, and remitting Alabama state and local sales, use, and/or lease tax on all taxable sales and leases into Alabama. By submitting this bid, the bidder is hereby certifying that they are in full compliance with act no. 2006-557, they are not barred from bidding or entering into a contract pursuant to 41-4-116, and acknowledges that the awarding authority may declare the contract void if the certification is false. All corporations must register to do business in Alabama with the Office of the Secretary of State. Their address is:

Office of the Secretary of State

P.O. Box 5616

Montgomery, AL 36103

(334) 242-5324

Fax: (334) 240-3138

<http://www.sos.state.al.us/index.aspx>

The Foreign Corporation form is online at

<http://www.sos.state.al.us/downloads/dl1.cfm>.

COST OF REMEDYING DEFECTS

All defects, indirect and consequential costs of correcting, removing or replacing any or all of the defective materials or equipment will be charged against the awarded vendor.

DELIVERY OF BID

Bids must be received in the Purchasing Office by the date and time specified on the bid cover. All bids will be accepted until the time and date stated on the bid cover. No bids will be accepted that extend past the time and date on the bid cover. The time of receipt shall be determined by the time clock stamp in the Purchasing Department. Bids submitted by U.S. Mail must be received by the City of Fairhope of Baldwin County, Alabama, in the City of Fairhope offices, 555 South Section St., Fairhope, Al., unless otherwise specified.

DELIVERY

The number of calendar days required for delivery after receipt of a purchase order shall be stated in the RFQ / ITB / RFP and /or Purchase Orders. When no time is stated in the document, the time shall be fourteen (14) calendar days after receipt of order. If a shipment is not made within the time period specified, the Purchase Order may be canceled.

ENVIRONMENTAL REQUIREMENTS

All products will be clearly labeled for their intended use. Each delivery of product or materials will include a Material Safety Data Sheet (MSDS) for all materials that require an MSDS. All manufacturers/distributors of hazardous substances, including any of the items listed on this bid/quote/ contract and subsequent award must include completed material safety data sheet (MSDS) for each hazardous material. Additionally, each container of hazardous materials must be appropriately labeled with:

- a) The identity of the hazardous material,

b) Appropriate hazard warnings, and manufacturer, importer, or other responsible party.

EQUIPMENT DEMONSTRATION

The City of Fairhope may require equipment/ product materials or service techniques to be demonstrated at a time, date and location to be specified by the City of Fairhope.

EQUIPMENT ELECTRICAL CERTIFICATION

All electrical equipment purchased shall conform to, and be identified in, the applicable standard(s), or otherwise be certified as applicable, as of the bid opening date and time, by Underwriters Laboratories, Inc. or other recognized laboratory facility. Bidder must provide satisfactory documentation with returned bid that all such equipment meets the applicable product standard or has otherwise been certified as outlined above. Unless indicated in the bid document, the above certification shall apply to the equipment itself, not the individual components of that equipment.

ERRORS IN BID

Bidders are assumed to be informed regarding conditions, requirements and specifications prior to submitting bids. Failure to do so will be at the bidder's risk. Bids already submitted may be withdrawn without penalty prior to bid opening. Errors discovered after the bid opening may not be corrected.

FORCE MAJEURE

Neither the City nor the awarded vendor shall be deemed in breach of any contract / Purchase Order or Agreement which may result from this proposal submission if it is prevented from performing any of the obligations hereunder by reason of Acts of God, acts of the public enemy, acts of superior governmental authority, strikes or labor disputes, floods, riots, rebellion, sabotage, or any similar other unforeseeable causes beyond its control and not due to its fault or negligence. Each party shall notify the other immediately in writing of the cause of such after the beginning period thereof. The awarded vendor may request cancellation and the City of Fairhope may grant the request if performance is prevented by any of the above referenced causes, or other unavoidable circumstances not attributable to the fault or negligence of the vendor. The burden of proof for such relief rests with the vendor. All correspondence pertaining to cancellation of a purchase order or term contract must be addressed to the City of Fairhope Purchasing Manager.

HAZARDOUS AND TOXIC SUBSTANCES

Bidder must comply with all applicable Federal, State, County and City laws, ordinances and regulations relating to hazardous and toxic substances, including such laws, ordinances and regulations pertaining to information hazardous and toxic substances, and as amended from time to time. Bidder shall provide the City of Fairhope with a "Material Safety Data Sheet" for all goods that carry one.

INDEMNITY

Indemnity: The awarded vendor hereby agrees to indemnify and save harmless the City of Fairhope, its officers, agent, and employees, from and against any and all liabilities, claims, demands, damages, fines, fees, expenses, penalties, suits, proceedings, actions and cost of actions, including reasonable attorneys fees for trial and on appeal, of any kind and nature, arising or growing out of, or in any way connected with the performance of this Contract / Agreement / Purchase Order, to the extent caused by a negligent act or omission of the awarded vendor, their agents, servants, employees, Subcontractors, or others associated with the awarded vendor. The awarded vendor shall be responsible for damage to any equipment excluded from this agreement, or damage or injury caused by any equipment excluded from this agreement, only to the extent that the damage or injury is caused by a negligent act or omission of the awarded vendor, or caused by failure of the awarded vendor's supplied product to perform as specified.

INSPECTION

All materials, workmanship, equipment, and supplies are subject to inspection and test at any source or time. Final inspection, acceptance or rejection will be made at delivery destination. Goods that do not meet specifications will be rejected unless substitutions have been approved by the City of Fairhope. Failure to inspect or to reject upon receipt, however, does not relieve the awarded vendor of liability. When subsequent tests, after receipt, are conducted and when such tests reveal a failure to meet specifications, the City of Fairhope will reject the goods and the awarded vendor shall immediately supply goods meeting specifications or the City of Fairhope may seek damages including but not limited to the testing expense, regardless of whether a part of or all of the goods have been consumed through the testing process. Rejected goods shall be removed by the awarded vendor promptly after rejection, at his expense. If not removed in fourteen (14) calendar days, they may be disposed of at the discretion of the City of Fairhope. Disposal costs will be the awarded vendor's responsibility.

INSPECTION OF PREMISES

At reasonable times, the City may inspect those areas of the awarded vendor's place of business that are related to the performance of a Contract / Agreement / Purchase Order. If the City makes such an inspection, the awarded vendor must provide reasonable assistance. The City of Fairhope reserves the right on demand and without notice all the vendor's files associated with a subsequent Contract / Agreement / Purchase Order where payments are based on the awarded vendor's record of time, salaries, materials, or actual expenses. This same clause will apply to any subcontractors assigned to the Contract / Agreement / Purchase Order.

INSURANCE

If a Contract / Agreement / Purchase Order results from this RFQ /ITB /RFP, or other form of solicitation, the awarded vendor shall maintain such insurance as will indemnify and

hold harmless the City of Fairhope from Workmen's Compensation and Public Liability claims from property damage and personal injury, including death, which may arise from the awarded vendor's operations under this Contract / Agreement / Purchase Order, or by anyone directly or indirectly employed by him/her.

INVITATION TO BID

Any provisions made in the RFQ / ITB / RFP, or other form of solicitation, supersedes any provisions outlined here in the General Terms and Conditions.

INVOICING, DELIVERY, PACKAGING

Invoices shall be prepared only after ordered materials have been delivered. All invoices must show the purchase order number. Unless otherwise specified in writing, vendors shall not ship any material without an authorized Purchase Order from the City of Fairhope Purchasing Department. All packages delivered must show the purchase order number. The awarded vendor will be required to furnish all materials, equipment and/or service called for at the bid price quoted. In the event the awarded vendor fails to deliver within a reasonable period of time, as determined by the City of Fairhope, the right is reserved to cancel the award and subsequent purchase order and purchase from the next lowest responsible bidder the items needed. The original awarded vendor will be back charged the difference between the original contract price and the price the City of Fairhope has to pay as a result of the failure to perform by the original awarded vendor. All bids will remain firm for acceptance for 60 days from the date of bid opening. Prices shall be net F.O.B., Prepaid and Allow, City of Fairhope chosen site, Baldwin County, Al. The title and risk of loss of the goods will not pass to the City of Fairhope until receipt and acceptance takes place at the F.O.B. point.

LABELING

Individual shipping cartons shall be labeled with the name "City of Fairhope", Purchase Order Number, and where applicable, Contract Number, date of manufacture, batch number, storage requirements, conditions, and recommended shelf life. Bidders are encouraged to offer product packaging with recycled content.

LOSS OR DAMAGE IN TRANSIT

Delivery by a vendor to a common carrier does not constitute delivery to the City of Fairhope. Any claim for loss or damage incurred during delivery shall be between the vendor and the carrier. The City of Fairhope accepts title only after satisfactory receipt at the delivery point. The City of Fairhope shall note all visible damages on the freight bill and may refuse the damaged goods. The vendor shall make immediate replacement of the damaged merchandise or be subject to damages for breach of contract. If damage is to a small portion of a total shipment and the City of Fairhope will not be inconvenienced because of the shortage, the vendor may be permitted by the Purchasing Manager to deduct the amount of damage or loss from its invoice, in lieu of replacement. Risk of loss

during delivery is borne by the vendor until the goods have been accepted by the City of Fairhope, unless otherwise specified in the RFQ / ITB / RFP or other form of solicitation.

MANDATORY SITE VISIT

If the RFQ / ITB /RFP or other form of solicitation requires a mandatory site visit, bidders must inspect the site where installation or service is to take place to obtain a full understanding of scope of work outlined therein. Date of site visit will be determined by the City of Fairhope.

MONITORING OF SERVICES

Performance of services will be monitored by the requisitioning department and/or the Purchasing Department, and evaluation reports may be filed with the Purchasing Department. Performance not meeting specifications will result in cancellation of Contract / Agreement / Purchase Order and may result in vendor being removed from the vendor list.

NONCONFORMING MERCHANDISE

When merchandise received from the lowest responsible bidder is not in accordance with the purchase order, it will be returned to the bidder, at bidder's expense.

NON-DESCRIMINATION

The City of Fairhope is an Equal Opportunity Employer and requires that all contractors comply with the Equal Employment Opportunity laws and the provisions of the Contract / Agreement / Purchase Order documents in this regard. The City also encourages and supports the utilization of Minority Business Enterprises on this and all public bids.

NON EXCLUSIVE

Unless otherwise specified, this Contract / Agreement / Purchase Order is considered a non-exclusive Contract /Agreement / Purchase Order between the parties.

NOTIFICATION AND ACCIDENT REPORTS

In the event of accidents of any kind, in the performance of a Contract / Agreement / Purchase Order, the awarded vendor shall notify the City of Fairhope immediately and furnish, without delay, copies of all such accident reports to the City of Fairhope. If in the performance of their Work, the awarded vendor fails to immediately report an accident to the City of Fairhope, of which the awarded vendor has knowledge of and which results in a fine levied against the City of Fairhope then the awarded vendor shall be responsible for all fines levied against the City of Fairhope.

PACKAGING

All goods must be packaged in new packing containers. Packing that meets the requirements of common carriers is acceptable, unless otherwise required. A packing slip or invoice must accompany all shipments and must reference the purchase order number.

PAYMENT

Invoices -- Upon completion of service and delivery of materials specified in the applicable purchase order, awarded vendor will submit an invoice and signed delivery ticket to:

City of Fairhope
Accounts Payable Department
P.O. Box 429
Fairhope, Al. 36533

All invoices must reference appropriate Purchase Order Numbers Payment of Invoice: All invoices received by the City of Fairhope are payable within thirty (30) days from the date of receipt by the City of Fairhope, provided they are approved by the City of Fairhope.

PAYMENT WITHHELD

Payment may be withheld until all items have been delivered and all requirements of the Contract / Agreement / Purchase Order have been fulfilled.

RECEIPT BY CITY OF FAIRHOPE

If not otherwise stated in the order, the City of Fairhope will be said to have received goods when they have been delivered, unloaded and placed on the agency's dock or if there is no dock, inside an accessible building, and signed for by an authorized City employee. Shipments will be checked against the receiving copy of the Purchase Order. If the purchase order requires grading certificates, USDA Stamps, or any proof of quality, such proof must accompany the shipment.

SET-UP AND INSTALLATION

Unless otherwise specified, bid / quotation to include cost of all uncrating, disposal of shipping materials, set-up, testing and initial instruction to agency personnel.

SPILL CLEAN UP

The awarded vendor shall be responsible for spillage caused by their negligence, which occurs during transit or unloading operations. The awarded vendor shall immediately report and clean up any spillage. Upon failure to do so, the awarded vendor shall remain responsible for all actual related costs.

PRODUCT TESTING

Vendor shall incur all cost involved in obtaining an Independent Laboratory Test if the City deems necessary during the term of the Contract / Agreement / Purchase Order. The City of Fairhope reserves the right to request a demonstration of any and all items bid before making the award.

PATENTS

Awarded Vendor guarantees that the sale and / or use of goods will not infringe upon any U.S. or foreign patent. Awarded vendor will at his / her own expense, indemnify, protect and save harmless the City of Fairhope, on any

patent claims arising from the purchase of goods or services.

PACKAGING

Unless otherwise specified, goods are to be packaged in cartons meeting federal specifications and shipped on non-returnable pallets.

PERMITS LICENSES AND CERTIFICATES

The awarded vendor is to procure all permits, licenses, and certificates, or any approvals of plans or specifications as may be required by Federal, State, Local Laws, ordinances, rules, and regulations, for the proper execution and completion of Work covered under the Contract / Agreement / Purchase Order.

PREPARATION OF BID

All bids / proposals shall be typewritten or in ink on the form(s) prepared by the City of Fairhope. Bids / proposals prepared in pencil will not be accepted. All bids / proposals must be signed by officials of the corporation or company duly authorized to sign bids / proposals. Any bid / proposal submitted without being signed will automatically be rejected. All corrections or erasures shall be initialed and dated by the person authorized to sign quotations / bids / proposals. If there are discrepancies between unit prices quoted and extensions, the unit price will prevail.

QUESTIONS / CONTACT

Commencing with the issuance of the RFQ / ITB / RFP, or other form of solicitation, no vendor or anyone acting on a vendor's behalf, shall make direct or indirect contact with City personnel or undertake any activities or take any action to otherwise promote its quotation / bid / proposal to the City or its personnel. All communications shall be made to the contact identified in the quotation / bid / proposal documents. Violation of this requirement may, at the City's sole and absolute discretion, be grounds for disqualifying a vendor from further consideration.

REJECTION OF BIDS

The City of Fairhope reserves the right to accept or reject any or all bids in whole or in part for any reason, to waive technicalities or informalities, or to advertise for new proposals, if, in the judgment of the awarding authority, the best interest of the City of Fairhope will be promoted thereby. Bidders may be disqualified and rejection of proposals may be recommended for any of (but not limited to) the following causes: Failure to use the bid forms furnished by the City of Fairhope, Lack of signature by an authorized representative on the bid form, Failure to properly complete the bid form and vendor compliance, Evidence of collusion among bidders, Unauthorized alteration of the bid form.

RIGHT TO AUDIT

The awarded vendor shall maintain documentation of all work performed. The awarded vendor shall make any and all documentation available to the City of Fairhope at all reasonable times, for inspections and audit by the City of

Fairhope, during the entire term of the Contract / Agreement / Purchase Order and for a period of Three (3) years after the expiration of the Contract / Agreement / Purchase Order.

SAMPLES

Bidders will not be required to furnish samples at the time of bid opening, unless specifically called for. The City of Fairhope reserves the right to request samples after bid opening to assist in the evaluation of proposals submitted.

SAFETY MEASURES

The awarded vendor shall take all necessary precautions for the safety of the City of Fairhope's and awarded vendor's employees at the Work site, and shall erect and properly maintain at all times, all necessary safeguards for the protection of the workmen and the public. The awarded vendor shall post signs warning against hazards in and around the Work site.

SUBSTITUTIONS

Substitutions on a purchase order shall require the approval of the Originating Buyer. The City of Fairhope reserves the right to reject at destination and hold at the vendor's risk and expense any goods supplied by the vendor which do not conform to the specification or description embodied in the order or are inferior in any respect to the good specified. Any good bought by sample which is inferior in quality to the sample submitted by vendor will be rejected. Any goods delivered that do not meet specifications may be returned to the vendor at its expense. When a good is returned, the vendor must make immediate replacement with acceptable merchandise or the City of Fairhope may seek remedies for default.

TABULATION

Bid results are posted on The City of Fairhope's web site: www.cofairhope.com. The awarded vendor will be sent a written notification via mail.

TAXES

Prices quoted shall be delivered prices, exclusive of all federal or state excise, sales, and manufacturer's taxes. The City will assume no transportation or handling charges other than specified in the RFQ, ITB, RFP or other form of solicitation. The City is tax exempt by law – Code of

Alabama 1975.

TERMINATION FOR CONVENIENCE

Any Contract / Agreement / Purchase Order may be terminated for convenience by the City of Fairhope, in whole or in part, by written notification to the awarded vendor.

TERMINATION FOR DEFAULT

Performance of Work under the Contract / Agreement / Purchase Order Agreement may be terminated by the City of Fairhope, in whole or in part, in writing, whenever the City of Fairhope determines that the awarded vendor has failed to meet the requirements of the Contract / Agreement

/ Purchase Order.

TERMINATION FOR NON-APPROPRIATION

Termination for Non-appropriation – The continuation of any financial obligation beyond the current fiscal year is subject to and contingent upon sufficient funds being appropriated, budgeted, and otherwise made available by the local source, State Legislature and/or federal sources. The City of Fairhope may terminate any financial obligation, and awarded vendor waives any and all claim(s) for damages, effective immediately upon receipt of written notice (or any date specified therein) if for any reason the City of Fairhope's funding from local, State and/or federal sources is not appropriated, withdrawn or limited.

TIME IS OF THE ESSENCE

The City of Fairhope and awarded vendor agree that time is of the essence in the performance of work called for under this Contract / Agreement / Purchase Order. The awarded vendor agrees that all work will be accomplished regularly, diligently and uninterrupted at such a rate of progress as will ensure full completion thereof within reasonable time periods.

TITLE

All titles, fees, as well as other charges, are to be paid by awarded vendor. Awarded vendor is to furnish prepaid certificate of title in the name of the City of Fairhope, Title shall change upon acceptance of delivery at the City of Fairhope approved delivery location.

VENDOR LIST

A vendor may be removed from the City of Fairhope's Bidders List if a vendor fails to respond to three (3) consecutive ITB's. A properly submitted "No Bid" is considered as a response and the vendor will receive credit for the response.

WARRANTY

The awarded vendor expressly warrants that all articles, materials, and work offered shall conform to each and every specification, drawing, sample, or other description which is furnished to or adopted by the City of Fairhope, and that it will be fit and sufficient for the purpose intended, merchantable, of good material and workmanship, and free from defects. The awarded vendor further warrants all items for a period of one year, unless otherwise stated, from the date of acceptance of the items delivered and installed or work completed. All repairs, replacements, or adjustments during the warranty period will be at the awarded vendor's sole expense. Awarded vendor will provide written warranty for all parts and labor for a period of (1) one year commencing from date of written acceptance of delivery by City of Fairhope. Awarded vendor will provide written copies of all other applicable warranties, such as, Manufacturer's warranty. Those warranties, if any, will be in addition to the awarded vendor's warranty, and the terms of which will not be altered by the awarded vendor's warranty.

violation thereof, are incorporated herein.

IMMIGRATION LAW

The Contractor agrees that it shall comply with all of the requirements of the **Beason-Hammon Alabama Taxpayer and Citizen Protection Act, Act No 2011-535, Alabama Code (1975) Section 31-13-1, et. Seq., (also known as the Alabama Immigration Act) see Section 31-13-9, and the provisions of said Act, including all penalties for**

ITEM VIII

Alabama Immigration Act Contract Requirements

1.0 Background

The **Beason-Hammon Alabama Taxpayer and Citizen Protection Act, Act No 2011-535, as amended by Act No 2012-491, Code of Alabama (1975) Section 31-13-1 through Section 31-13-30** (also known as and hereinafter referred to as "the Alabama Immigration Act") is applicable to contracts with the City of Fairhope, Alabama. All business entities entering into contracts with

the City of Fairhope, Alabama will comply with the Alabama Immigration Act.

2.0 Definitions

ALIEN. Any person who is not a citizen or national of the United States, as described in 8 U.S.C. § 1101, et seq., and any amendments thereto.

BUSINESS ENTITY. Any person or group of persons employing one or more persons performing or engaging in any activity, enterprise, profession, or occupation for gain, benefit, advantage, or livelihood, whether for profit or not for profit. Business entity shall include but not be limited to the following:

- a. Self-employed individuals, business entities filling articles of incorporation, partnerships, limited partnerships, limited liability companies, foreign corporations, foreign limited partnerships, foreign liability companies authorized to transact business in this state, business trusts, and any business entity that registers with the Secretary of State.
- b. Any business entity that possesses a business license, permit, certificate, approval, registration, charter, or similar form of authorization issued by the state, any business entity that is exempt by law from obtaining such a business license, an any business entity that is operating unlawfully without a business license.

CONTRACTOR. A person, employer, or business entity that enters into an agreement to perform any service or work or to provide a certain product in exchange for valuable consideration. This definition shall include, but not be limited to, a general contractor, subcontractor, independent contractor, contract employee, project manager, or a recruiting or staffing entity.

EMPLOYEE. Any person directed, allowed, or permitted to perform labor or service of any kind by an employer. The employees of an independent contractor working for a business entity shall not be regarded as the employees of the business entity, for the purposes of this chapter. This term does not include any inmate in the legal custody of the state, a county, or a municipality.

EMPLOYER. Any person, firm, corporation, partnership, joint stock association, agent, manager, representative, foreman, or other person having control or custody of any employment, place of employment, or of any employee, including any person or entity employing any person for hire within the State of Alabama, including a public employer. This term shall not include the occupant of a household contracting with another person to perform casual domestic labor within the household.

E-VERIFY. The electronic verification of federal employment authorization program of the Illegal Immigration Reform and Immigrant Responsibility Act of 1996, P.L. 104-208, Division c, Section 403 (a); 8 U.S.C. §1324(a), and operated by the United States Department of Homeland Security, or its successor program.

STATE-FUNDED ENTITY. Any governmental entity of the state or a political subdivision thereof or any other entity that receives any monies from the state or a political subdivision thereof; provided, however, an entity that merely provides a service or a product to any governmental entity of the state or a political subdivision thereof, and receives compensation for the same, shall not be considered a state-funded entity.

SUBCONTRACTOR. A person, business entity, or employer who is awarded a portion of an existing contract by a contractor, regardless of its tier.

UNAUTHORIZED ALIEN. An alien who is not authorized to work in the United States as defined in 8 U.S.C. § 1324a (h) (3) .

3.0 Mandatory Clause

All contracts or agreements to which the state, a political subdivision, or state-funded entity are a party shall include the following clause:

"By signing this contract, the contracting parties affirm, for the duration of the

agreement, that they will not violate federal immigration law or knowingly employ, hire for employment, or continue to employ an unauthorized alien within the state of Alabama. Furthermore, a contracting party found to be in violation of this provision shall be deemed in breach of the agreement and shall be responsible for all damages resulting therefrom."

For purposes of this section, "contract" shall mean a contract awarded by the state, any political subdivision thereof, or any state-funded entity that was competitively bid or would, if entered into by the state or an agency thereof, be required to be submitted to the Contract Review Permanent Legislative Oversight Committee.

4.0 Contracts Involving Business Entity, or Employer

As a condition for the award of any contract, grant, or incentive by the state, any political subdivision thereof, or any state-funded entity to a business entity or employer that employs one or more employees, the business entity or employer shall not knowingly employ, hire for employment, or continue to employ an unauthorized alien within the State of Alabama.

As a condition for the award of any contract, grant, or incentive by the state, any political subdivision thereof, or any state-funded entity to a business entity or employer that employs one or more employees within the state of Alabama, **the business entity or employer shall provide documentation establishing that the business entity or employer is enrolled in the E-Verify program.** During the performance of the contract, the business entity or employer shall participate in the E-Verify program and shall verify every employee that is required to be verified according to the applicable federal rules and regulations.

5.0 Contracts Involving Subcontracting

Any subcontractor on a project paid for by contract, grant, or incentive by the state, any political subdivision thereof, or any state-funded entity shall not knowingly employ, hire for employment, or continue to employ an unauthorized alien within the State of Alabama and shall also enroll in the E-Verify program prior to performing any work on the project. Furthermore, during the performance of the contract, the subcontractor shall participate in the E-Verify program and shall verify every employee that is required to be verified according to the applicable federal rules and regulations. This subsection shall only apply to subcontractors performing work on a project subject to the provisions of this section and not to collateral persons or business entities hired by the subcontractor.

6.0 Proof of E-Verify documentation

Proof of E-Verify will be in the form of a copy of the signed Memorandum Of Understanding (MOU) generated upon completion of the E-Verify program.